

operation & maintenance instruction

“MU-2A” VALVE, PC. NO. 559000

JUNE, 1990

Supersedes issue dated August, 1983

NOTE: The following description and operation is based on this device and its components being new or this device and its components having been repaired, tested, installed and maintained in accordance with instructions issued by this and any other applicable Wabtec Corporation publications.

⚠ WARNING: At the time any part is replaced in this device, the operation of the complete device must pass a series of tests prescribed in the latest issue of the applicable Wabtec Test Specification. At the time this device is applied to the brake equipment arrangement, a stationary vehicle test must be made to insure that this device functions properly in the total brake equipment arrangement. (Consult your local Wabtec Representative for identity of the test specification, with latest revision date, that covers this device.)

IMPORTANT: Only Wabtec supplied parts are to be used in the repair of this device in order to obtain satisfactory operation. Commercially available non-O.E.M. parts are unacceptable.

NOTE: The part numbers and their associated descriptions are the property of Wabtec Corporation and may not be replicated in any manner or form without the prior sole written consent of an Officer of Wabtec Corporation.

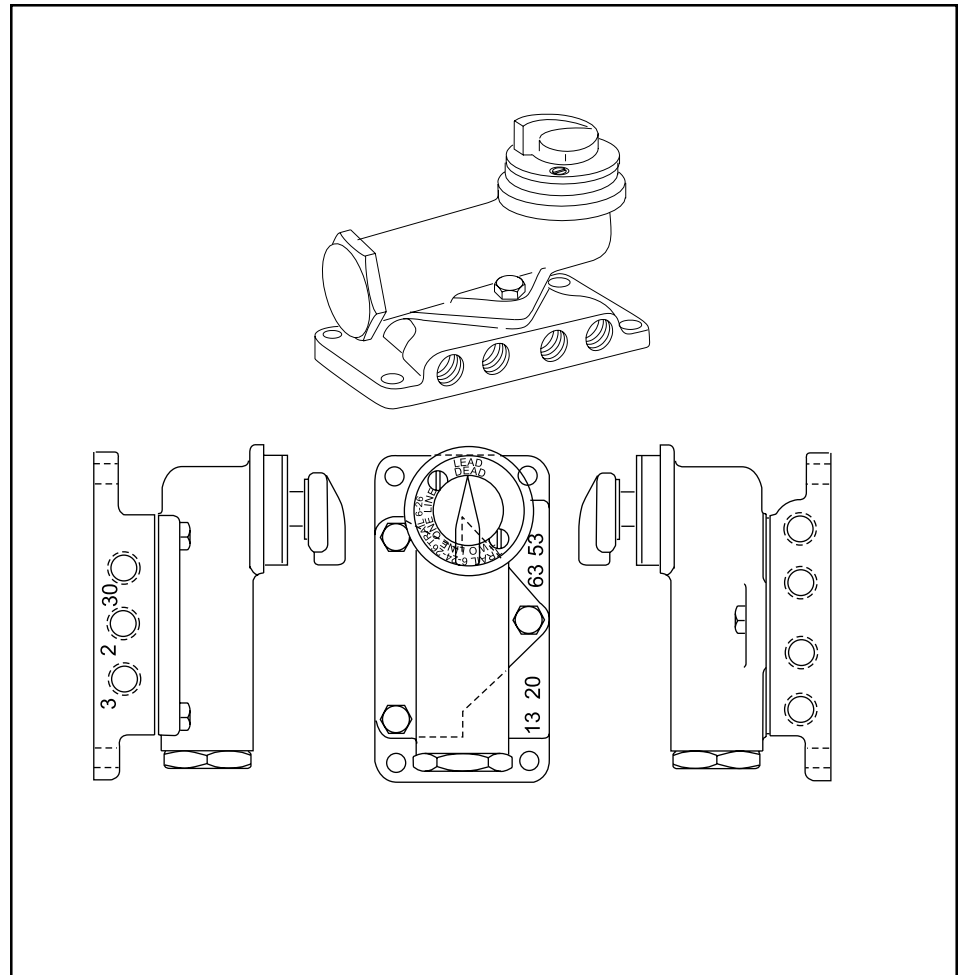

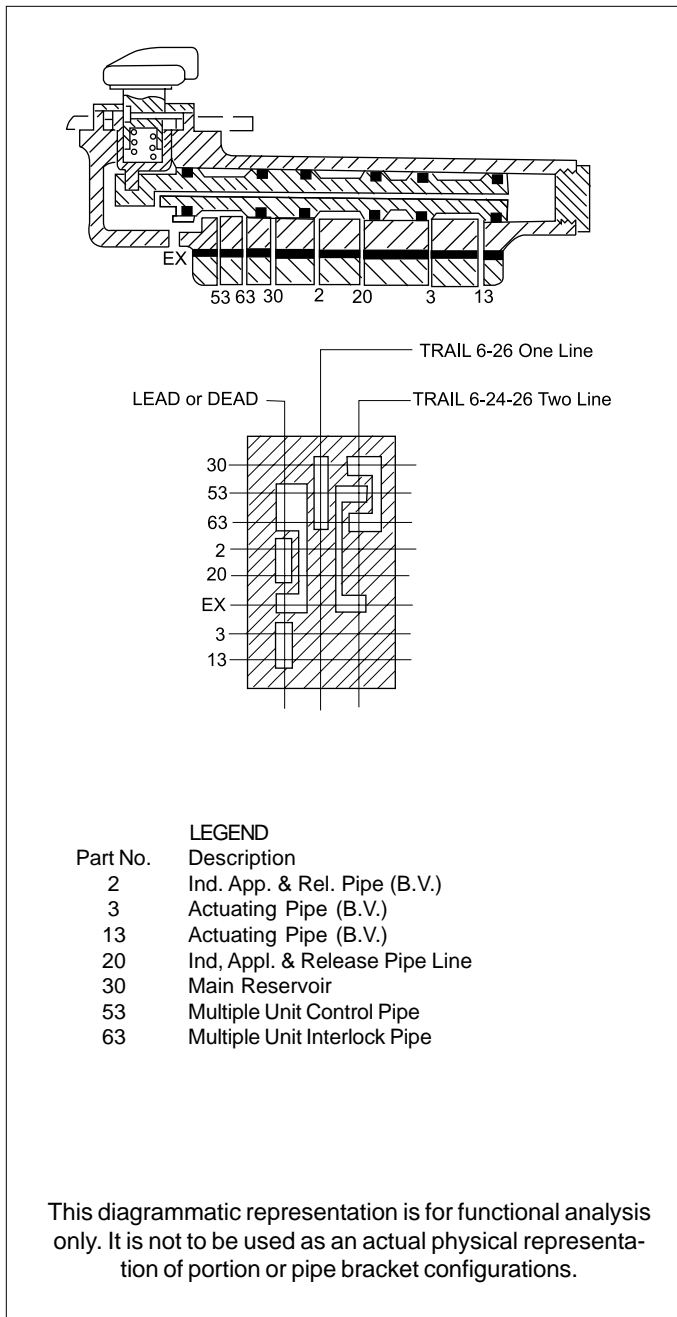

Figure 2 - Diagrammatic View

1.0 DESCRIPTION

Designed for use in equipment arrangements where the air pressure does not exceed 150 psig, the "MU-2A" Valve, Part No. 559000, is comprised of an "MU-2A" Valve Portion, Part No. 559338 and a Pipe Bracket, Part No. 559305. The "MU-2A" Valve Portion is mounted on the Pipe Bracket and secured in place by three 3/8" hex. head cap screws.

The Pipe Bracket is semi-permanently mounted on the vehicle. All pipe connections are made directly to the Pipe Bracket. Seven 3/8"-18 NPT pipe taps are provided for pipe connections. The port numbers are indicated on the pipe bracket and are identified in the chart shown in Figure 2.

When arranged in a locomotive equipment arrangement with an "F-1" Selector Valve or an "F-1" Selector Valve Portion, for which it acts as a pilot, the "MU-2A" Valve conditions the locomotive equipped with "26-L" Type Brake Equipment to operate in multiple unit service with locomotives equipped with "6-SL", "6-BL", "26", and "24-RL" Type Locomotive Air Brake Equipment. The three positions provided by this "MU-2A" Valve are "LEAD-DEAD", "TRAIL 6-26 ONE LINE" and "TRAIL 6-24-26 TWO LINE". The various positions are indicated on the escutcheon plate of the Valve Portion.

IMPORTANT: Special Installation procedures are required when installing the "MU-2A" Valve in an equipment arrangement. Consult your Wabtec Corporation Representative for information on specific applications.

2.0 OPERATION (Figure 2)

2.1 "LEAD-DEAD" POSITION

In "LEAD-DEAD" position, main reservoir air piped to port 30 is blocked by the spool in the valve. Ports 53 and 63 are connected to atmosphere. Independent brake control air from the independent brake valve is connected to port 2 of the "MU-2A" Valve and thus through the spool to port 20. The actuating pipe air from the independent brake valve is connected to port 3 of the MU-2A Valve and thus through the spool to port 13.

2.2 "TRAIL 6-26 ONE LINE" POSITION

When the "MU-2A" Valve is placed in "TRAIL 6-26 ONE LINE" position, main reservoir air piped to port 30 of the "MU-2A" Valve, is connected to ports 53 and 63. All other connected ports are "blanked off" at the spool valve.

2.3 "TRAIL 6-24-26 TWO LINE" POSITION

When the "MU-2A" Valve is placed in "TRAIL 6-24-26 TWO LINE" position, main reservoir air piped to port 30 is connected via the spool valve to port 63. Port 53 is connected to atmosphere in the spool valve and all other port connections are "blanked off" at the spool valve.

3.0 MAINTENANCE SCHEDULE

IMPORTANT: The "MU-2A" Valve Portion should be removed from the equipment arrangement, be taken to the shop, be thoroughly disassembled, the parts cleaned, in-



operation & maintenance instruction

spected, lubricated and then reassembled using **NEW** Wabtec Corporation Rubber parts and other specified **NEW** Wabtec Corporation parts. The assembled "MU-2A" Valve Portion is then to be tested for correct operation. Maintenance is to be performed according to the following vehicle application schedule, or more frequently if service conditions so indicate.

RECOMMENDED TYPE OF APPLICATION	FREQUENCY - AT LEAST ONCE EVERY
Locomotive	24 Months
Passenger (Interstate)	24 Months
Transit	24 Months

4.0 PARTS CATALOG AND REPLACEMENT PART INFORMATION

4.1 PARTS CATALOG

4.1.1 When ordering replacement parts for the "MU-2A" Valve, Part No. 559000 and/or the "MU-2A" Valve Portion, Part No. 559338, refer to the current issue of the Wabtec Corporation Parts Catalog 3213-1.

NOTE: The reference numbers in this publication and those used in the Parts Catalog may differ. Check the descriptive part name and part number to be sure that the desired part is ordered.

4.2 REPLACEMENT PARTS

4.2.1 IMPORTANT: To obtain satisfactory operation and reliability of the "MU-2A" Valve and/or the "MU-2A" Valve Portion, **ONLY** Wabtec Corporation replacement parts are to be used in the maintenance of these devices.

5.0 SAFETY PROCEDURES AND WARNINGS

Regular owner-operating property and shop safety procedures **MUST BE** followed when working on the "MU-2A" Valve and "MU-2A" Valve Portion.

The work area should be clean and free of debris.

WARNING

The following statements of warning apply all or in part whenever the symbol  appears in the maintenance procedures. Failure to observe these precautions may result in serious injury to those performing the work and/or bystanders.

- **The use of an air jet, which must be less than 30 p.s.i.g., to blow parts clean or to blow them dry after being cleaned with a solvent will cause particles of dirt and/or droplets of the cleaning solvent to be**

airborne. Wire brushing may also cause particles of dirt, rust, and scale to become airborne. These conditions may cause skin and/or eye irritation.

- **When using an air jet, do not direct it toward another person. Improper use of air jet could result in bodily injury.**
- **Personal eye protection must be worn when performing any work on this device or its components parts to avoid any possible injury to the eyes.**
- **The use of solvents as cleaning agents and the use of lubricants can involve health and/or safety hazards. The manufacturers of the solvents and lubricants should be contacted for safety data (such as OSHA Form OSHA-20 or its equivalent). The recommended precautions and procedures of the manufacturers should be followed.**
- **When performing any test or work on devices or equipment while they are on the vehicle (on car test, etc.) special precautions must be taken to insure that vehicle movement will not occur which could result in injury to personnel and/or damage to equipment.**
- **Assembly may be under a spring load. Exercise caution during disassembly so that no parts "Fly Out" and cause bodily injury.**
- **All air supply and/or electric current to this device and/or to any components part must be cut-off before this device and/or any component part is removed from the equipment arrangement.**
- **"Bottled" up air under pressure (even though air supply is cut-off) may cause gaskets and/or particles of dirt to become airborne and an increase in sound level when this device and/or any component part is removed from the equipment arrangement.**
- **Personal eye and ear protection must be worn and care taken to avoid possible injury when performing any work on this device and/or component part.**
- **To prevent receiving electrical shock when performing electrical tests, hands must be clear of electrical components, contacts and housing and there must be no bodily contact with the work bench. Failure to heed this warning could result in severe injury or death.**

6.0 CLEANING SOLVENT & LUBRICANT

6.1 The solvent used to clean reusable parts of the "MU-2A" Valve Portion **MUST BE** an aliphatic organic solution,

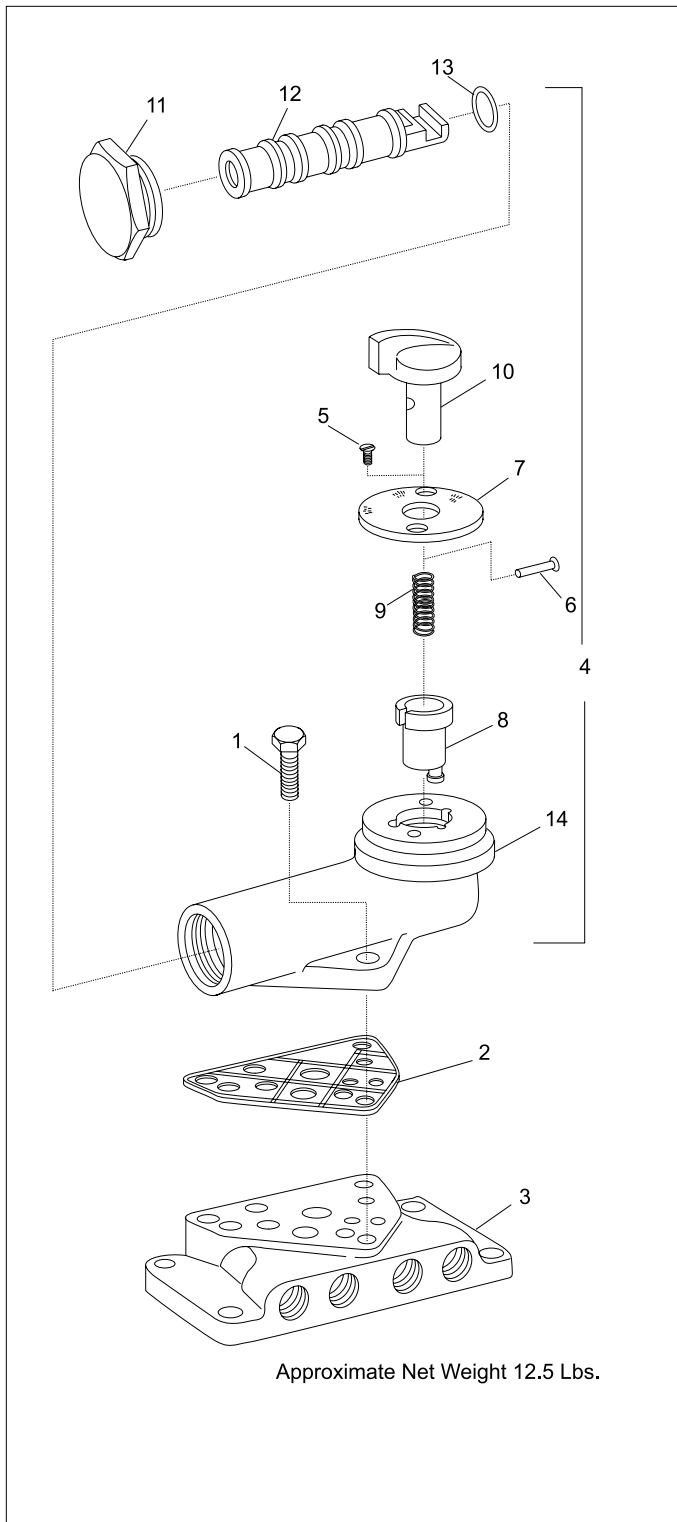

Figure 3 - Exploded View

such as mineral spirits or naphtha, that will dissolve oil or grease and that will permit all parts to be cleaned without abrasion.

6.2 Number 2 Silicone Grease, Wabtec Corporation Specification M-7680-2, such as Dow Corning Corporation Dow Corning 55M (formerly Molykote 55M) is used for the lubrication of the o-rings, o-ring grooves, and the bearing surface of the bushing into which the o-ring assembly is to be installed.

7.0 MAINTENANCE PROCEDURES - "ON-CAR"

7.1 PARTS REQUIRED

7.1.1 A NEW "MU-2A" Valve Portion, Part No. 559338, or an "MU-2A" Valve Portion, Part No. 559338, that has been repaired or serviced and that has passed the procedures of the current issue of the Wabtec Corporation Test Specification T-2430-O.

7.1.2 A NEW pipe bracket mounting gasket, Part No. 558987.

NOTE: The pipe bracket mounting gasket, Part No. 558987, is included in the Rubber Repair Parts Kit, Part No. 561084.

⚠ 7.2 REMOVAL AND INSTALLATION OF THE "MU-2A" VALVE PORTION - "ON VEHICLE"

7.2.1 **IMPORTANT:** Apply vehicle handbrake(s) and chock vehicle wheels to prevent vehicle movement. Suitable warning placards indicating that work is being performed are to be placed in the work area and on and about the vehicle. **ALL** air supply to the "MU-2A" Valve is to be cut-off.

(Figure 3)

7.2.2 Clean the exterior surfaces of the "MU-2A" Valve of **ALL** free dirt by wiping with a clean, lint-free cloth, or by blowing the surfaces clean with a low pressure jet of clean dry air.

7.2.3 Providing adequate support for the "MU-2A" Valve Portion (4), which weighs approximately 12 pounds, remove it from the pipe bracket (3) by first removing the three 3/8" x 1 1/4" hex head cap screws (1).

7.2.4 Remove and **SCRAP** the pipe bracket mounting gasket (2).

7.2.5 Visually inspect the pipe bracket (3) for damage. Pay particular attention to the exposed mounting face to be sure that it is clean and that the ports are not restricted. If necessary, the ports may be blown out with a low-pressure



operation & maintenance instruction

jet of clean, dry air. Exercise care so that no dirt is blown into the ports. It is not necessary to remove the pipe bracket unless it is damaged. If found damaged, the pipe bracket is to be replaced with a NEW pipe bracket portion. A NEW pipe bracket portion is to be installed following the procedures of the owner-operating property and the builder of the vehicle.

7.2.6 Remove all protective material from a NEW or repaired and tested "MU-2A" Valve Portion (4). Be sure that **ALL** tape is removed from **ALL** ports.

7.2.7 Install a NEW pipe bracket mounting gasket (2) and the "MU-2A" Valve Portion (4) on the pipe bracket (3) and secure them in place by installing three $\frac{3}{8}$ " x $1\frac{1}{4}$ " hex head cap screws (1). Equally tighten the cap screws.

7.2.8 Provide adequate protection to prevent dirt and/or moisture from entering the removed "MU-2A" Valve Portion and transport it to the shop for repair.

7.2.9 IMPORTANT: Whenever an "MU-2A" Valve Portion is removed from an equipment arrangement for any reason, and it is reinstalled or replaced with a NEW or repaired and tested "MU-2A" Valve Portion, a stationary vehicle test **MUST BE** made to be sure that the "MU-2A" Valve Portion and the "MU-2A" Valve function properly in the total brake equipment arrangement.

7.2.10 **IMPORTANT:** Remove ALL warning placards and wheel chocks before attempting to move the vehicle.

8.0 "MU-2-A" VALVE PORTION - MAINTENANCE PROCEDURES - "IN-SHOP"

IMPORTANT: When performing the procedures which follow, DO NOT use hard or sharp tools to remove o-rings or gaskets. Exercise care so that no parts are damaged.

⚠ WARNING: When performing the procedures which follow, springs may be placed under tension or compression. Exercise care so that no parts are inadvertently expelled from the assembly. Inadvertently expelled parts may cause bodily injury and damage.

⚠ 8.1 DISASSEMBLY

8.1.1 Remove the two Number 10 x 1/2 inch flat head machine screws (5) which secure the escutcheon plate (7) to the valve body (14).

8.1.2 Remove the control handle (10), escutcheon plate (7) and the detent pin (6) assembly as a unit from the valve body (14).

8.1.3 Remove the detent pin (6) and escutcheon plate (7)

from the control handle (10).

8.1.4 Remove the spring (9) from the operating shaft (8).

8.1.5 Remove the operating shaft (8) from the valve body (14).

8.1.6 Remove the $1\frac{1}{2}$ " cap nut (11) from the valve body (14).

8.1.7 Remove the valve (12) with o-rings (13) as a unit from the valve body (14).

8.1.8 Remove and SCRAP the six $\frac{15}{16}$ " O.D. o-rings (13) from the valve (12).

8.1.9 If the mounting gasket (2) is still attached to the mounting face of the body (14) it is to be removed and SCRAPPED.

⚠ 8.2 CLEANING AND INSPECTING

8.2.1 NON-REUSABLE PARTS

8.2.1.1 **IMPORTANT:** ALL o-rings and the mounting gasket are to be SCRAPPED and replaced with NEW Wabtec Corporation parts during the assembly procedure.

8.2.1.2 A Rubber Parts Kit, which includes the required o-rings and mounting gasket is available by ordering Part No. 561084. Refer to the current issue of Parts Catalog 3213-1 for information on the kit parts.

8.2.2 BODY

8.2.2.1 Wash the body, using the cleaning solvent as described in Section 6.1.

A clean, lint-free cloth that has been saturated with the prescribed cleaning solvent may be used to assist in the cleaning of the interior and exterior surfaces of the body.

8.2.2.2 After the body has been cleaned, it **MUST BE** completely dried. Use a low pressure jet of clean dry air to blow the body dry.

8.2.2.3 Inspect the body for damage. Pay particular attention to the bushings in the body. If the body is damaged in any way, or if it is in such a condition that may result in the unsatisfactory operation of the "MU-2A" Valve Portion, it is to be SCRAPPED and replaced with a NEW body.

8.2.3 REMAINING PARTS

8.2.3.1 Wash all of the remaining parts using the cleaning solvent as described in Section 6.1.



8.2.3.2 The spring may be wire brushed to assist in the removal of any dirt, rust or scale.

8.2.3.3 After the parts are cleaned, they **MUST BE** completely dried. Use a low pressure jet of clean dry air to blow the parts dry.

8.2.3.4 Inspect the parts.

8.2.3.4.1 Replace the spring if it is rusted, pitted, distorted, damaged in any way, or if it has taken a permanent set. Refer to the current issue of Parts Catalog 3213-1 for spring information.

8.2.3.4.2 Replace any part that is cracked, cut, bent, broken, shows signs of excessive wear, is damaged in any way, or that is in such a condition that may result in the unsatisfactory operation of the "MU-2A" Valve Portion.

⚠ 8.3 ASSEMBLY

8.3.1 Coat the surfaces of six NEW $15/16$ " O.D. o-rings (13) with Number 2 Silicone Grease, Wabtec Corporation Specification M-7680-2. Also fill the o-ring grooves of the spool valve (12) and lightly coat the o-ring bearing surfaces of the spool valve bushing of the body with the lubricant.

8.3.2 Install the six NEW lubricated $15/16$ " O.D. o-rings (13) into their grooves on the spool valve (12). Any excess lubricant may be removed by wiping with a clean, dry, lint-free cloth.

8.3.3 With the milled slot in the spool valve (12) facing upward, insert the valve (12) with o-rings (13) as a unit into the body (14) until the milled slot is approximately in the center of the operating shaft bushing of the body (14).

8.3.4 Lightly lubricate the stem surfaces of the operating shaft (8) with Number 2 Silicone Grease, Wabtec Corporation Specification M-7680-2. Insert the operating shaft (8) into the valve body (14). The top of the operating shaft **MUST BE** flush with the escutcheon plate mounting face of the body.

8.3.5 Rotate the operating shaft (8) in the valve body (14) until the slot in the top of the operating shaft is in line with one of the slots in the escutcheon plate mounting face on the valve body.

8.3.6 Insert the spring (9) into the operating shaft (8).

8.3.7 Place the escutcheon plate (7) on the handle (10) with the printing on the escutcheon plate in the same upward position, facing the handle knob, as when it was removed. Insert the detent pin (6) into the handle (10) to secure the escutcheon plate (7) on the handle (10).

8.3.8 Insert the handle (10) with escutcheon plate (7) and detent pin (6) as a unit into the operating shaft (8). Secure the escutcheon plate (7) to the valve body (14) with the two Number 10 x $1/2$ " flat head machine screws (5).

8.3.9 Operate the handle (10) several times to make certain that the operating shaft (8) has engaged the valve (12) and both move freely.

8.3.10 Install the $1 1/2$ " hex. head cap nut (11) into the valve body (14).

8.4 TESTING AND ADDITIONAL INFORMATION

8.4.1 IMPORTANT: After the "MU-2A" Valve Portion has been assembled, and before it is returned to service, IT MUST pass a series of tests following the procedures of the current issue of the Wabtec Corporation Test Specification T-2430-O.

8.4.2 IMPORTANT: Whenever the "MU-2A" Valve Portion, Part No. 559338, is removed from an equipment arrangement for any reason, and it is reinstalled or replaced with a NEW or repaired and tested "MU-2A" Valve Portion, a NEW pipe bracket mounting gasket **MUST BE** used. This gasket is shown as Ref. 2 in Figure 3.

8.4.3 IMPORTANT: Whenever the "MU-2A" Valve Portion, Part No. 559338, is removed from an equipment arrangement for any reason, and it is reinstalled or replaced with a NEW or repaired and tested "MU-2A" Valve Portion, a stationary vehicle air brake test **MUST BE** made to be sure that the "MU-2A" Valve Portion and the "MU-2A" Valve function properly in the total equipment arrangement.

8.4.4 Consult your Wabtec Corporation Representative if additional information is required.

WABCO Locomotive Products

1001 Air Brake Avenue • Wilmerding, PA 15148

(412) 825-1000 • Fax (412) 825-1019

www.wabtec.com