

Operation & Maintenance Instruction

#8 VENT VALVE with BRANCH PIPE TEE, Part No. 579076

JANUARY, 2001

Supersedes Issue dated November, 1988

NOTE: The following description and operation is based on this device and its components being new or this device and its components having been repaired, tested, installed and maintained in accordance with instructions issued by this and any other applicable Wabtec Corporation publications.

⚠ WARNING: At the time any part is replaced in this device, the operation of the complete device must pass a series of tests prescribed in the latest issue of the applicable Wabtec Test Specification. At the time this device is applied to the brake equipment arrangement, a stationary vehicle test must be made to insure that this device functions properly in the total brake equipment arrangement. (Consult your local Wabtec Representative for identity of the test specification, with latest revision date, that covers this device.)

IMPORTANT: Only Wabtec supplied parts are to be used in the repair of this device in order to obtain satisfactory operation. Commercially available non-O.E.M. parts are unacceptable.

NOTE: The part numbers and their associated descriptions are the property of Wabtec Corporation and may not be replicated in any manner or form without the prior sole written consent of an Officer of Wabtec Corporation.

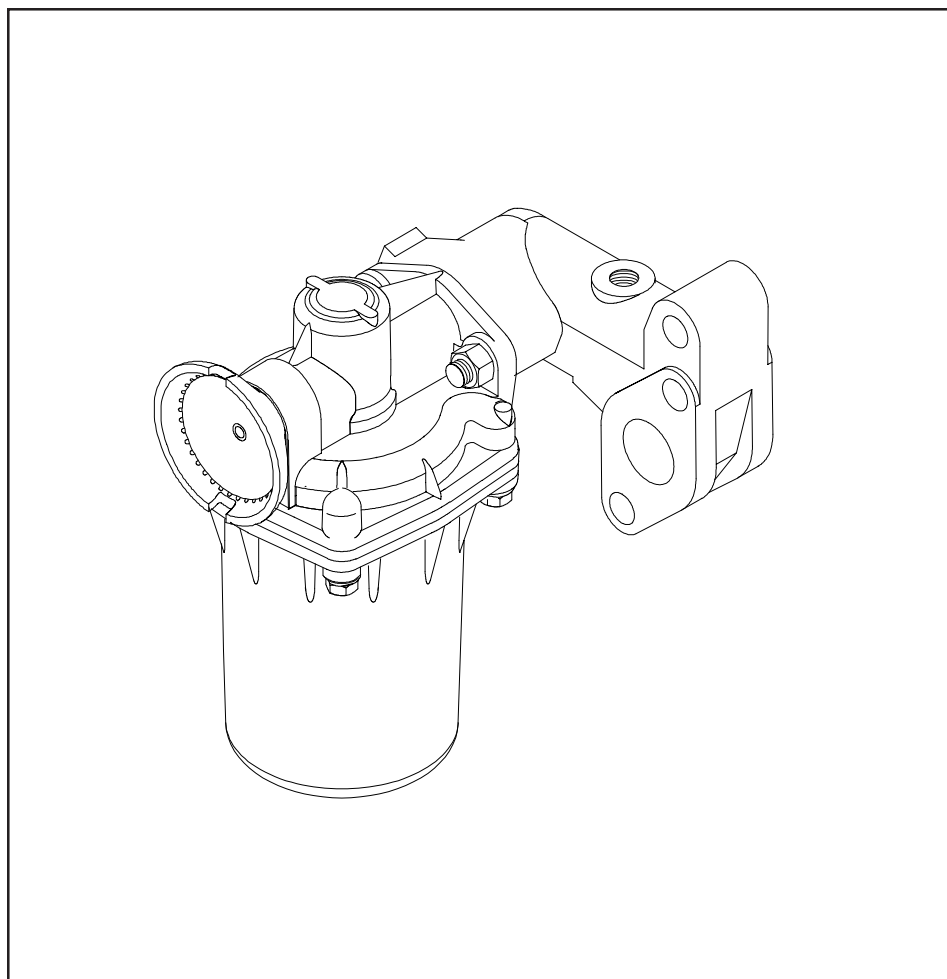



Operation & Maintenance Instruction

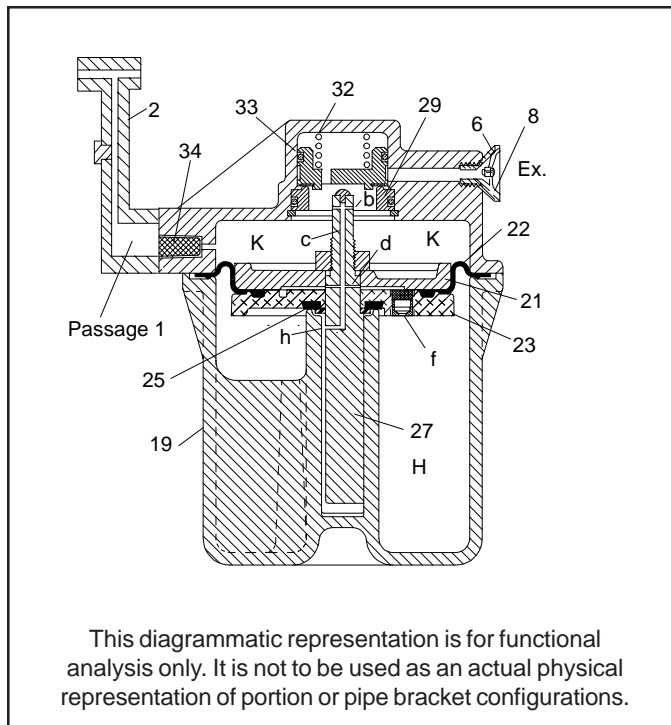

Figure 1 - Diagrammatic View

1.0 DESCRIPTION

1.1 Designed for use in specific equipment arrangements where the air pressure does not exceed 150 psig, the #8 Vent Valve with Branch Pipe Tee, Pc.No. 579076, consists of a Branch Pipe Tee, Pc.No. 579007; a #8 Vent Valve Portion, Pc.No. 567820; and a Vent Protector Assembly, Pc.No. 566738.

1.2 The Branch Pipe Tee is arranged so that it can be semi-permanently installed into a specific equipment arrangement. Two 1 1/4" Flanges are provided for pipe attachment and a 1" Flange Face is provided for the mounting of the #8 Vent Valve Portion. A 3/8"-18NPT tap is provided in the top of the tee for the attachment of piping to another device such as a Stop Insuring Unit or a Cut-Off Pilot Valve. When this tap is not used in the piping of an equipment arrangement it **MUST BE plugged**.

1.3 The #8 Vent Valve Portion, which is secured to its mounting Flange on the Branch Pipe Tee by two 1/2" hex nuts, is a diaphragm type valve which depletes brake pipe air locally at a rapid rate to assist in propagating an emergency brake application whenever the main line of brake pipe pressure is reduced at an emergency rate. Operation of the Vent Valve Portion at one or more vehicle locations aids in producing an emergency rate of brake pipe pressure

reduction at the next vehicle and actuation of the Vent Valve Portion(s) on each succeeding vehicle assists in a fast transmission of an emergency brake signal through an open, continuous line brake pipe.

1.4 The Vent Protector Assembly is installed in the exhaust port of the #8 Vent Valve Portion.

1.5 **IMPORTANT: Consult your Wabtec Corporation Representative for piping and installation specifications and information for specific applications.**

2.0 OPERATION (Refer to Figure 1)

2.1 CHARGING

Brake pipe air flows from the branch pipe tee 2 into passage 1 to charge chamber K. Piston 23 moves into release position permitting spring 32 to seat vent valve exhaust valve 33. Brake pipe air flows through cross-section passage b, passage c, d, and f to charge the vent valve chamber H.

Flow of air through passage h is cut off at seal 25 due to the pressure in chamber K forcing the piston downward toward the lower pressure in chamber H.

2.2 SERVICE

When air pressure is gradually reduced out of passage 1, the vent valve volume H reduces in pressure an amount corresponding to this pressure drop in order to maintain this valve in a stabilized position. When the pressure in chamber K is reduced, air from chamber H bleeds down through passages c, d, f, h, and b, stabilizing the vent valve piston 23 against movement to emergency position during service brake applications.

2.3 RELEASE AND RECHARGE AFTER SERVICE APPLICATION

During a pressure reduction in passage 1, the vent valve volume H reduces in order to follow the brake pipe pressure reduction. The Vent Valve Portion is recharged as previously described under "charging".

2.4 EMERGENCY POSITION

When an emergency rate of brake pipe reduction is effective in passage 1, air in chamber H of the Vent Valve Portion cannot flow through passages h, f, d, c, and b at the same rate as chamber K is being evacuated. This differential of pressure across piston 23 moves the piston stem 27 to contact and unseat exhaust valve 33. A large and direct passage is provided for brake pipe air in passage 1 to flow



Operation & Maintenance Instruction

through chamber K to atmosphere. This local rapid venting of brake pipe air accelerates the emergency reduction of brake pipe pressure serially and rapidly through the train by assisting in the prompt movement of similar valves on other vehicles into an emergency position.

2.5 RELEASE AFTER EMERGENCY

A predetermined reset delay time is designed into the valve by the established exhaust rate of chamber H. Once the spring 32 returns the exhaust valve 33 to its seat 29 and diaphragm assembly to its normal position. The Vent Valve Portion can then be recharged as previously described under "charging".

3.0 MAINTENANCE SCHEDULE

IMPORTANT: At least **ONCE** every twenty four months, or more frequently if service conditions so indicate, the #8 Vent Valve Portion with Vent Protector Assembly is to be removed from the equipment arrangement and taken to the shop, be completely disassembled, the parts cleaned, inspected, lubricated and then reassembled using **NEW** parts as specified. The assembled Portion is then to be tested for correct operation.

4.0 PARTS CATALOG AND REPLACEMENT PARTS INFORMATION

4.1 PARTS CATALOG INFORMATION

IMPORTANT: When ordering replacement parts for the #8 Vent Valve with Branch Pipe Tee, Pc.No. 579076, or any of its Component Portions, refer to the current issue of the Wabtec Corporation Parts Catalog 3211-4, S. 19.

NOTE: The reference numbers used in this publication and those used in the Parts Catalog(s) may differ. Check the descriptive part name and part number to be sure that the desired part is ordered.

4.2 REPLACEMENT PARTS

IMPORTANT: To obtain satisfactory operation and reliability of the #8 Vent Valve Portion with Branch Pipe Tee, Pc.No. 579076 and its Component Portions, **ONLY** Wabtec Corporation replacement parts are to be used in the maintenance of this Device and/or its Component Portions.

5.0 SAFETY PROCEDURES AND WARNINGS

Regular Owner-Operating Property and Shop Safety Procedure **MUST BE** followed when performing any work on the #8 Vent Valve with Branch Pipe Tee or any of its Component Portions.

The work area is to be clean.

⚠ WARNING: The following statements of warning apply all or in part wherever the symbol ⚠ appears in the maintenance procedures. Failure to observe these precautions may result in serious injury to those performing the work and/or bystanders.

- The use of an air jet, which must be less than 30 p.s.i.g., to blow parts clean or to blow them dry after being cleaned with a solvent will cause particles of dirt and/or droplets of the cleaning solvent to be airborne. Wire brushing may also cause particles of dirt, rust, and scale to become airborne. These conditions may cause skin and/or eye irritation.
- When using an air jet, do not direct it toward another person. Improper use of air jet could result in bodily injury.
- Personal eye protection must be worn when performing any work on this device or its components parts to avoid any possible injury to the eyes.
- The use of solvents as cleaning agents and the use of lubricants can involve health and/or safety hazards. The manufacturers of the solvents and lubricants should be contacted for safety data (such as OSHA Form OSHA-20 or its equivalent). The recommended precautions and procedures of the manufacturers should be followed.
- When performing any test or work on devices or equipment while they are on the vehicle (on car test, etc.) special precautions must be taken to insure that vehicle movement will not occur which could result in injury to personnel and/or damage to equipment.
- Assembly may be under a spring load. Exercise caution during disassembly so that no parts "Fly Out" and cause bodily injury.
- All air supply and/or electric current to this device and/or to any components part must be cut-off before this device and/or any component part is removed from the equipment arrangement.



Operation & Maintenance Instruction

- “Bottled” up air under pressure (even though air supply is cut-off) may cause gaskets and/or particles of dirt to become airborne and an increase in sound level when this device and/or any component part is removed from the equipment arrangement.
- To prevent receiving electrical shock when performing electrical tests, hands must be clear of electrical components, contacts and housing and there must be no bodily contact with the work bench. Failure to heed this warning could result in severe injury or death.
- An adequate support or lifting device must be available to support the device and/or valve portion(s) during removal, installation and maintenance procedures.

6.0 CLEANING SOLVENT AND LUBRICANT

6.1 The solvent used for cleaning the reusable parts of the #8 Vent Valve Portion **MUST BE** an aliphatic, organic solution, such as mineral spirits or naphtha, that will dissolve oil and grease and that will permit all parts to be cleaned without abrasion.

IMPORTANT: Cleaning solvents are **ONLY** to be used in well ventilated areas.

6.2 The following lubricants **MUST BE** available:

6.2.1 Number 2 Silicone Grease, Wabtec Corporation Specification M-7680-2, such as Dow Corning Corporation Dow Corning 55, is required for the lubrication of o-rings, o-ring grooves, the piston stem and the bearing surfaces of the bushings into which o-ring assemblies are installed.

6.2.2 A compound consisting of one part graphite, Wabtec Corporation Specification M-7695-2 (AAR Specification M-913), such as Superior Flake Graphite Co. - Superflake Number 597; J. Dixon Crucible Co. - Microfyne Graphite; National Carbon Co. - Number 38 or Number 39 Graphite, and two parts of oil (SAE-20) by weight is required for the lubrication of the piston choke plug prior to the assembly of the choke plug in the piston.

6.2.3 Locking Sealant, Wabtec Corporation Specification M-7499-5, such as Loctite Corporation TL-242, is required when assembling the jam nut on the stem of the piston to secure the diaphragm and diaphragm follower in place.

6.2.4 Pipe Sealant with Teflon, Wabtec Corporation Specification M-7499-15, such as Loctite Corporation Pipe Sealant with Teflon, is used on the threads of the Vent Protector Assembly.

January, 2001

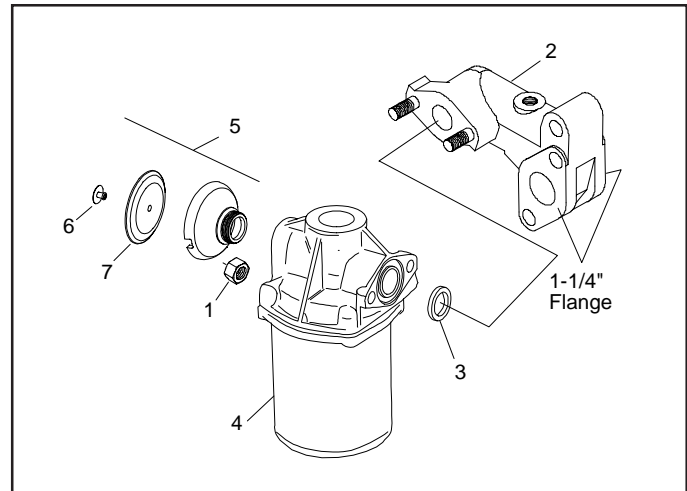

Figure 2 - Vent Protector - Exploded View

IMPORTANT: Sealant is to be applied following the procedures stipulated by the Sealant manufacturer.

7.0 SPECIAL TOOLS

7.1 In addition to the regular shop tools, the following **MUST BE** available:

- 7.1.1 No. 3 TRUARC Retaining Ring Pliers.
- 7.1.2 An $1\frac{1}{16}$ " open end wrench.
- 7.1.3 A perfectly flat cast iron lapping plate.
- 7.1.4 Float emery.
- 7.1.5 Piece of $\frac{1}{16}$ " diameter drill rod.

8.0 MAINTENANCE PROCEDURES - “ON-CAR”

IMPORTANT: “On-Car” maintenance is to be limited to the removal and replacement of the #8 Vent Valve Portion with Vent Protector Assembly, Pc.No. 567513. No “On-Car” repairs to the Portion are permitted.

8.1 PARTS REQUIRED

8.1.1 A NEW #8 Vent Valve Portion with Vent Protector Assembly, Pc.No. 567513, or a #8 Vent Valve Portion with Vent Protector Assembly, Pc.No. 567513, that has been overhauled and that has been tested according to the procedures of one of the current issues of Wabtec Corporation Test Specification as listed in Section 10.



Operation & Maintenance Instruction

IMPORTANT: The #8 Vent Valve Portion is tested as Pc.No. 567820 which covers a #8 Vent Valve Portion less Vent Protector Assembly. After the Portion has passed all test procedures of the applicable Test Specification, the Vent Protector Assembly is installed in the exhaust port of the Vent Valve Portion. This assembly is now the #8 Vent Valve Portion with Vent Protector Assembly, Pc.No. 567513.

8.1.2 A NEW 1" Flange Fitting Gasket, Pc.No. 93986.

⚠ 8.2 REMOVAL AND REPLACEMENT OF THE #8 VENT VALVE PORTION WITH VENT PROTECTOR ASSEMBLY

8.2.1 IMPORTANT: ALL owner-operating property safety procedures and the safety procedures and warnings as listed in Section 5.0 of this publication **MUST BE** adhered to.

8.2.2 IMPORTANT: Chock the wheels of the vehicle and apply hand brake(s) to prevent any unintentional vehicle movement.

Place suitable warning placard indicating that work is being performed on and about the vehicle.

Cut-off ALL air supply to the #8 Vent Valve Portion.

8.2.3 Refer to Figure 2. Remove **ALL** free dirt from the exterior surfaces of the #8 Vent Valve and Branch Pipe Tee by wiping with a clean, dry, lint-free cloth. A low pressure jet of clean, dry air may be used to blow the surfaces clean.

8.2.4 Provide adequate support to hold the #8 Vent Valve Portion with Vent Protector Assembly (4, 5). Carefully remove the two 1/2" hex nuts (1) which secure the #8 Vent Valve Portion (4) on the Branch Pipe Tee (2), then remove the #8 Vent Valve Portion with Vent Protector Assembly (4, 5), as a unit, from the Branch Pipe Tee (2).

8.2.5 Remove and **SCRAP** the 1" flange fitting gasket from its groove in the mounting face of the #8 Vent Valve Portion (4).

8.2.6 Visually inspect the Branch Pipe Tee (2) for damage. Pay particular attention to the Vent Valve Portion mounting flange of the Tee. Be sure that it is clean and not damaged in any way. The Branch Pipe Tee (2) need not be removed from the equipment arrangement unless it is damaged. Should it be necessary to replace the Branch Pipe Tee (2), owner-operating property instructions are to be followed.

8.2.7 Remove **ALL** protective materials from a NEW or overhauled and tested #8 Vent Valve Portion with Vent

Protector Assembly, Pc.No. 567513. Be sure that **ALL** protective tape is removed from the mounting face and from the vent protector seal.

Be sure that the wire mesh strainer is in the port on the mounting face of the #8 Vent Valve Portion. This strainer is a part of the #8 Vent Valve Portion. If the strainer is not in place, obtain a NEW strainer, Pc.No. 568058, and install it in place or return the #8 Vent Valve Portion with Vent Protector Assembly, Pc.No. 567513, to stores and obtain one with the strainer in place.

8.2.8 Install a NEW 1" flange fitting gasket, Pc.No. 93986, into its groove on the mounting face of the Vent Valve Portion (4).

8.2.9 Carefully install the #8 Vent Valve Portion with Vent Protector Assembly and gasket in position on the Branch Pipe Tee (2) and secure the parts in place by installing two 1/2" hex nuts (1). Equally tighten the nuts.

8.2.10 Provide adequate protection to prevent dirt and/or moisture from entering the removed #8 Vent Valve Portion with Vent Protector Assembly and transport it to the shop area for maintenance.

8.2.11 **IMPORTANT:** Whenever the #8 Vent Valve Portion with Vent Protector Assembly is removed from an equipment arrangement for any reason, and it is reinstalled or replaced with a NEW or repaired and tested Portion, a stationary vehicle test **MUST BE** performed to be sure that the #8 Vent Valve Portion and the #8 Vent Valve with Branch Pipe Tee function properly in the total equipment arrangement.

8.2.12 **IMPORTANT:** Whenever the #8 Vent Valve Portion with Vent Protector Assembly is removed from an equipment arrangement for any reason, and it is re-installed or replaced with a NEW or repaired and tested Portion, a NEW mounting gasket (1" flange fitting gasket, Pc.No. 93986) **MUST BE** used. This gasket **IS NOT** a part of the Portion and **MUST BE** ordered as an individual item.

8.2.13 **IMPORTANT:** Remove **ALL** warning placards and wheel chocks before attempting to move the vehicle.

9.0 #8 VENT VALVE PORTION - MAINTENANCE PROCEDURES - "IN-SHOP"

IMPORTANT: When performing the procedures which follow, **DO NOT** use hard or sharp metal tools to remove o-rings, gaskets, seals or the diaphragm. Exercise care so that **NO** damage is done to metal surfaces.

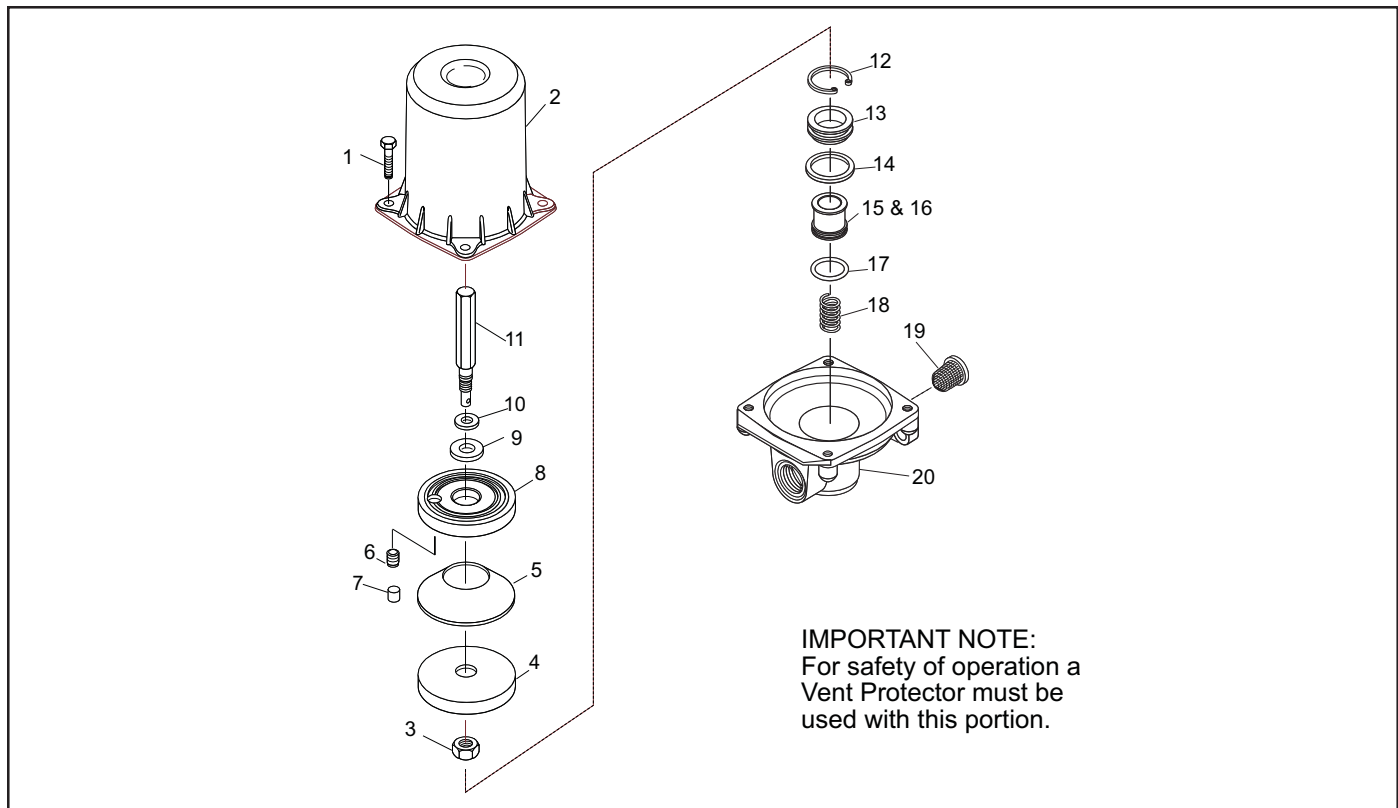

Figure 3 - Vent Valve Portion - Exploded View

⚠ 9.1 DISASSEMBLY

9.1.1 Refer to Figure 2. Remove the vent protector assembly (5, 6, 7) from the #8 Vent Valve Portion (4) as a unit.

9.1.2 Refer to Figure 3. Remove the four $\frac{3}{8}$ " x 1" hex head cap screws (1) that secure the diaphragm housing (2) to the body (20).

9.1.3 Remove the diaphragm housing with the diaphragm piston assembly (2 to 11) as a unit from the body (20).

9.1.4 Remove the diaphragm piston assembly (3 thru 11) from the diaphragm housing (2).

9.1.5 Disassemble the diaphragm piston assembly as follows:

9.1.5.1 Hold the piston stem (11) with an $\frac{11}{16}$ " open end wrench and remove the $\frac{1}{2}$ " lock nut (3) from the piston stem (11).

9.1.5.2 Remove the diaphragm follower (4), diaphragm (5), piston with seal and felt filter assembly (6, 7, 8) and washer (10) from the piston stem (11).

9.1.5.3 Remove the felt filter (7) and rubber seal (9) from the piston (8).

9.1.5.4 **SCRAP** the seal (9), the diaphragm (5) and the felt filter (7).

⚠ WARNING: During the procedure which follows, spring (18) will be placed under tension. Exercise care so that **NO** part is inadvertently expelled from the assembly. Inadvertently expelled parts could possibly cause bodily injury and/or damage to equipment.

9.1.6 **CAREFULLY** depress and hold the exhaust valve seat (13), valve (15), and spring (18) into the body (20), then, using the No. 3 TRUARC Retaining Ring Pliers, remove the retaining ring (12) from the body (20). Slowly release the hold on the exhaust valve seat (13).

9.1.7 Remove the exhaust valve seat with o-ring (13, 14), exhaust valve with o-ring (15, 17) and spring (18) from the body (20).

NOTE: If the exhaust valve sticks, use a piece of stiff wire or rod with the end bent and insert it through the drilled hole to hook the valve and pull it out of the body.



Operation & Maintenance Instruction

9.1.8 Remove and SCRAP the 1³/₄" O.D. o-ring (14) from the exhaust valve seat (13).

9.1.9 Remove and SCRAP the 1¹/₂" O.D. o-ring (17) from the exhaust valve (15).

9.1.10 Remove and SCRAP the 1" flange fitting gasket (Reference No. 3 in Figure 3) from the mounting face of the body (20) if it is still in its groove. This gasket **IS NOT** a part of the Portion.

9.1.11 Remove the strainer (19) from the port in the mounting flange of the body (20).

⚠ 9.2 CLEANING AND INSPECTING

9.2.1 VENT PROTECTOR ASSEMBLY (Figure 2)

9.2.1.1 Use a lint free cloth or rag that has been saturated with the cleaning solvent described in Section 6.1 to clean the surfaces of the assembly.

9.2.1.2 After cleaning, visually inspect the assembly. If the body of the assembly is damaged in any, replace the assembly with a NEW Wabtec Corporation part.

If the seal (7) is damaged in any way, or is cracked or torn, it **MUST BE** replaced. This can be accomplished by lifting the seal and using the proper tool cut off the head of the pop rivet. Remove the rivet (6) and seal (7) from the body. Use a NEW Seal (7) and secure it in place with a NEW ³/₁₆" x 1¹/₂" pop rivet (6).

9.2.2 NON-REUSABLE PARTS

9.2.2.1 The felt filter (7) is to be SCRAPPED and replaced with a NEW Wabtec Corporation part.

9.2.2.2 ALL gaskets, o-rings, the diaphragm and non-metal seals are to be replaced with NEW Wabtec Corporation parts.

IMPORTANT: A Rubber Parts Repair Kit, Pc.No. 578886, is available for the repair of the #8 Vent Valve Portion less Vent Protector Assembly, Pc.No. 567820. Check the Parts Catalog listed in Section 4.0 for items in this kit.

9.2.3 PISTON

9.2.3.1 Visually inspect the piston assembly to be sure it is the current design, Part No. 660353. The current piston design is equipped with 1¹/₈" choke plug, Part No. 585361.

If the piston is of older design, not equipped with a choke plug, it is to be **SCRAPPED** and replaced with the **NEW** piston assembly, Part No. 660353, which includes a Piston, Part No. 660386, and a 1¹/₈" Choke Plug with 0.0160" Drill, Part No. 585361; and a Felt Filter, Part No. 660354.

9.2.3.2 If the piston assembly is of the current design, it **MUST BE** cleaned and inspected as follows:

9.2.3.2.1 If not already removed, remove and **SCRAP** the Felt Filter (6). Remove the 1¹/₈" choke plug (7) from the piston (8) and place it in a bath of the prescribed cleaning solvent, as described in Section 6.1, to soak.

9.2.3.2.2 Clean the piston (8) by washing with the prescribed cleaning solvent, as described in Section 6.1.

9.2.3.2.3 After the piston has been cleaned, it **MUST BE** completely dried. Use a low pressure jet of clean, dry air to blow the piston dry.

9.2.3.2.4 Inspect the piston. Replace the piston if it is damaged in any way, or shows signs of excessive wear.

NOTE: If the piston is damaged, it is recommended that a **NEW** Piston Assembly, Part No. 660353, be used. This assembly includes the piston, felt filter, and choke plug.

9.2.3.2.5 If the piston passes the inspection procedure, it may be reused.

9.2.3.2.6 Remove the choke plug (6) from the solvent bath and blow it completely dry using a low pressure jet of clean, dry air.

9.2.3.2.7 Inspect the choke plug for damage. Check to be sure that the size of the orifice, which **MUST BE** 0.0160" Drill, has not changed. **SCRAP** and replace the choke plug if it is damaged in any way, or if the size of the orifice has changed. **DO NOT USE HARD METAL TOOLS TO CLEAN THE CHOKE.**

9.2.3.2.8 Apply a light coating of the oil and graphite compound, as described in Section 6.2.2, to the threads of the choke plug. Install the lubricated choke plug in place in the piston. The choke plug **MUST BE** installed in the piston its full travel to permit for the installation of the felt filter. When properly installed, the lead end of the choke plug will be exposed on the flat side of the piston.

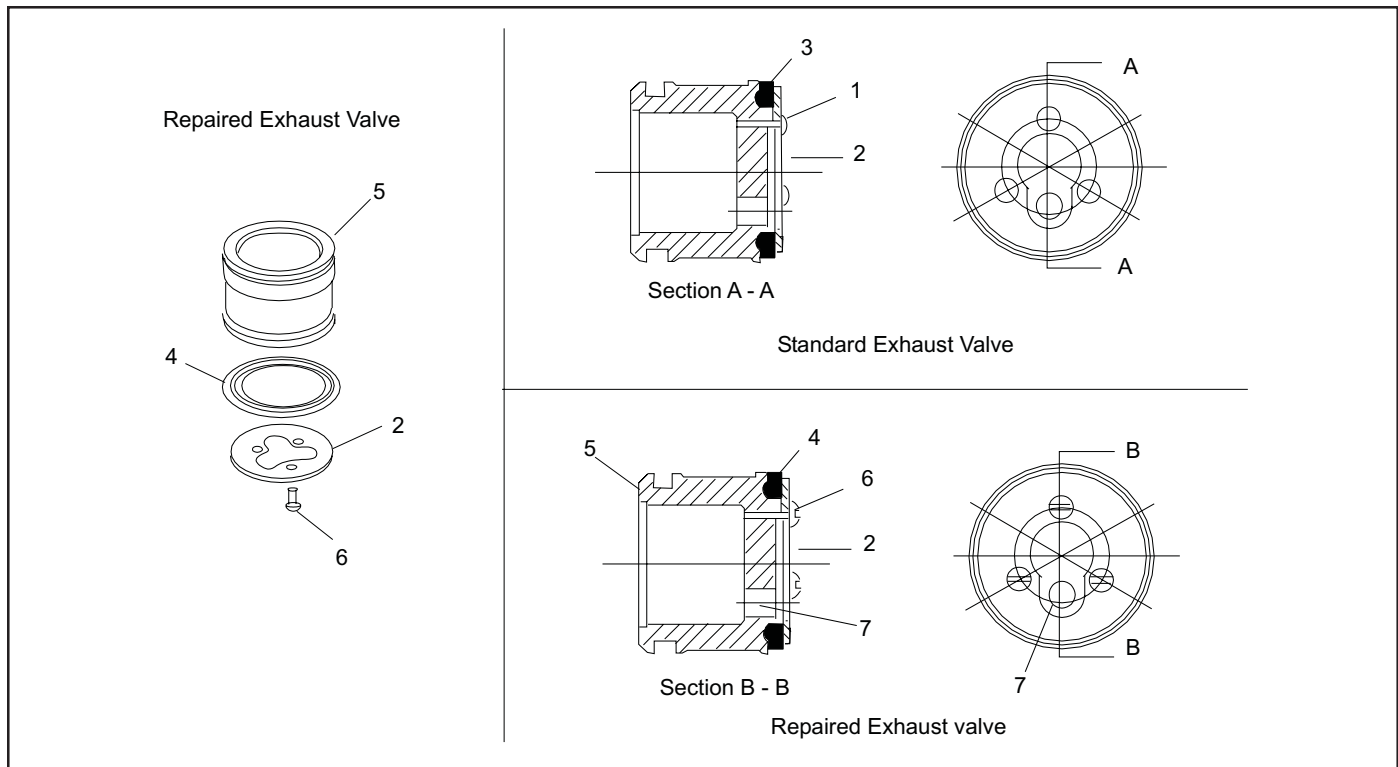

Figure 4 - Exhaust Valve - Drawing G-100

9.2.4 PISTON STEM

9.2.4.1 **IMPORTANT: ALL** old locking sealant **MUST BE** removed from the threads of the piston stem (11). Follow the instructions of the Sealant manufacturer for the proper cleaning procedure, or clean the part by washing with the cleaning solvent as described in Section 6.1. Be sure all old sealant is removed.

9.2.4.2 After the part has been cleaned, it **MUST BE** completely dried. Use a low pressure jet of clean dry air to blow the parts dry.

9.2.4.3 Inspect the part. Replace the piston stem if it is bent, shows signs of excessive wear, or if it is damaged in any way. Replace any part that is damaged in any way, or if it is in such a condition that may result in the unsatisfactory operation of the #8 Vent Valve Portion.

9.2.5 REMAINING PARTS (Figure 3)

9.2.5.1 Wash ALL of the remaining parts in a bath of cleaning solvent as described in Section 6.1.

9.2.5.2 The spring may be wire brushed to assist in the removal of any dirt, rust or scale.

9.2.5.3 After the parts have been cleaned, they **MUST BE** completely dried. Use a low pressure jet of clean, dry air to blow the parts dry.

9.2.5.4 Inspect the spring. Replace it if it is rusted, pitted, distorted or if it has taken a permanent set. Refer to Parts Catalog listed in Section 4.0 for spring identification and information.

9.2.5.5 Inspect the retaining ring (12). It **MUST** “snap” into its groove during assembly. Replace it if it is not elastic enough to hold securely.

9.2.5.6 Inspect the exhaust valve seat (13) to be sure that it is not scratched, scored or otherwise damaged. If the valve seat requires reconditioning, the following recommended procedure may be utilized:

9.2.5.6.1 Use a perfectly flat cast iron lapping plate. Apply float emery to the entire surface of the plate. Condition the plate by rubbing in with a piece of flat brass such as a brass rotary valve which has a ground finished surface.

9.2.5.6.2 Lap the valve seat on the lapping plate by holding the valve flat and using a rotary motion.



Operation & Maintenance Instruction

IMPORTANT: No more than 0.010" may be removed from the original thickness. Original thickness is 0.469".

9.2.5.6.3 Wipe the valve seat clean with a clean, soft, lint-free cloth that has been saturated with the cleaning solvent described in Section 6.1.

9.2.5.6.4 Blow the valve seat dry and clean of all foreign matter with a low pressure jet of clean, dry air.

9.2.5.7 Inspect the seal (16) on the exhaust valve (15). If it is cracked, cut, or worn excessively, it **MUST BE** replaced according to the following procedure:

9.2.5.7.1 Refer to Figure 4. If driven fasteners are installed, use a piece of $1/16$ " diameter rod to drive out the three fasteners (1). **SCRAP** the fasteners. If screws are installed, remove the three screws (6).

Remove the seal retainer (2) and seal (4). **SCRAP** the seal.

9.2.5.7.2 Place a NEW seal (4) Pc.No. 568992 on the exhaust valve (5) with the bead of the seal in the groove of the exhaust valve.

9.2.5.7.3 Position the retainer (2) Pc.No. 568995 in place on the seal (4).

⚠ WARNING: Make certain that the retainer does not cover the exhaust valve hole (7) in any way. If the hole is covered, improper valve operation could result, leading to possible injury to personnel and/or equipment.

9.2.5.7.4 Using three NEW #3 self tapping screws (6) Pc.No. 584117, secure the seal retainer (2) in place. Torque the screws to a maximum of 9.0 inch pounds.

9.2.5.8 Reject and replace any part that is cracked, cut, broken worn excessively, damaged in any way, or that is in such a condition that may result in unsatisfactory operation of the Portion and/or #8 Vent Valve Portion with Branch Pipe Tee.

⚠ 9.3 ASSEMBLY (Refer to Figure 4)

9.3.1 Using Number 2 Silicone Grease, Wabtec Corporation Specification M-7680-2, coat the surfaces of a NEW $1\frac{1}{2}$ " O.D. o-ring (17) and a NEW $1\frac{3}{4}$ " O.D. o-ring (14). Fill the o-ring grooves on the exhaust valve (15) and the exhaust valve seat (13) and lightly coat the bearing surfaces of the bushing in the body (20) with the lubricant.

9.3.2 Install the NEW lubricated $1\frac{1}{2}$ " O.D. o-ring (17) into its groove on the exhaust valve (15). Install the lubricated $1\frac{3}{4}$ " O.D. o-ring (14) into its groove on the exhaust valve seat (13). Remove any excess lubricant by wiping with a clean, lint-free cloth.

9.3.3 Insert the exhaust valve spring (18), the exhaust valve (15) with o-ring (17) and the exhaust valve seat (13) with o-ring (14) into the body (20).

9.3.4 Exercising care so that no parts fly out and cause an injury, **CAREFULLY** secure the parts in place with the retaining ring (12).

NOTE: The retaining ring **MUST** "snap" tightly in its groove.

9.3.5 Assemble the diaphragm piston assembly (3 to 11) as follows:

9.3.5.1 Install a NEW rubber seal (9) and a NEW felt filter (7) into the piston (8).

9.3.5.2 Place the washer (10) and piston (8) on the piston stem (11) with the felt filter (7) toward the threaded end of the piston stem.

9.3.5.3 Place a NEW diaphragm (5) on the piston (8) with the bead of the diaphragm (5) in the groove of the piston (8).

9.3.5.4 Place the diaphragm follower (4) on the diaphragm (5) with the ribbed side of the follower toward the threaded end of the piston stem (11).

9.3.5.5 Secure the parts in place with the $1/2$ " lock nut (3). Torque the lock nut to 30-35 foot pounds.

9.3.5.6 Lightly lubricate the piston stem (11) with a thin film of #2 Silicon Grease, Wabtec Corporation Specification M-7680-02 (Dow Corning 55 O-ring Lubricant or equivalent). Install the diaphragm piston assembly (3 to 11) into the diaphragm housing (2) with the bead of the diaphragm (5) in the groove in the diaphragm housing (2).

9.3.5.7 Place the body (20) in position on the diaphragm housing (2) and secure it in place by installing four $3/8$ " x 1" hex head screws (1). Equally tighten the screws (1).

9.3.5.8 Install the strainer (19) into the port on the mounting face of the body (20).



Operation & Maintenance Instruction

IMPORTANT: The #8 Vent Valve Portion is now ready to be tested. The Vent Protector Assembly will be installed after the testing procedure has been completed. This #8 Vent Valve Portion, less Vent Protector Assembly is tested as Pc.No. 567820.

10.0 TESTING AND ADDITIONAL INFORMATION

10.1 After the #8 Vent Valve Portion, Pc.No. 567820, has been assembled **BUT BEFORE** it is returned to service it **MUST** pass a series of tests following the procedure of the current issue of one of the following Wabtec Corporation Test Specifications:

Test Spec. No	Test Rack
T-2720-0	AB
T-2703-0	4C
T-2674-0	4B

10.2 After the #8 Vent Valve Portion has passed the prescribed tests, install the Vent Protector Assembly in place in the exhaust port of the body. Apply a light coating of Pipe Sealant with Teflon, Wabtec Corporation Specification M-7499-15 to the threads of the Vent Protector Assembly before installing it in the body of the Vent Valve Portion. The #8 Vent Valve Portion with Vent Protector Assembly is covered by Pc.No. 567513.

10.3 IMPORTANT: Whenever the #8 Vent Valve Portion with Vent Protector Assembly is removed from an equipment arrangement for any reason, and it is reinstalled or replaced with a NEW or repaired and tested portion, a NEW mounting gasket **MUST BE** used. This 1" flange fitting gasket is shown as reference 3 in Figure 2.

10.4 IMPORTANT: Whenever the #8 Vent Valve Portion with Vent Protector Assembly is removed from an equipment arrangement for any reason, and it is reinstalled or replaced with a NEW or repaired and tested portion, a stationary vehicle test **MUST BE** made to be sure that the Portion and #8 Vent Valve with Branch Pipe Tee function properly in the total brake equipment arrangement.

10.5 Consult your Wabtec Corporation Representative if additional information is required.

WABCO Locomotive Products

1001 Air Brake Avenue • Wilmerding, PA 15148
 (412) 825-1000 • Fax (412) 825-1019
www.wabtec.com