

operation & maintenance instruction

#8 VENT VALVE, Part No. 581602

OCTOBER, 1984

Supersedes issue dated June, 1979

NOTE: The following description and operation is based on this device and its components being new or this device and its components having been repaired, tested, installed and maintained in accordance with instructions issued by this and any other applicable Wabtec Corporation publications.

⚠ WARNING: At the time any part is replaced in this device, the operation of the complete device must pass a series of tests prescribed in the latest issue of the applicable Wabtec Test Specification. At the time this device is applied to the brake equipment arrangement, a stationary vehicle test must be made to insure that this device functions properly in the total brake equipment arrangement. (Consult your local Wabtec Representative for identity of the test specification, with latest revision date, that covers this device.)

IMPORTANT: Only Wabtec supplied parts are to be used in the repair of this device in order to obtain satisfactory operation. Commercially available non-O.E.M. parts are unacceptable.

NOTE: The part numbers and their associated descriptions are the property of Wabtec Corporation and may not be replicated in any manner or form without the prior sole written consent of an Officer of Wabtec Corporation.

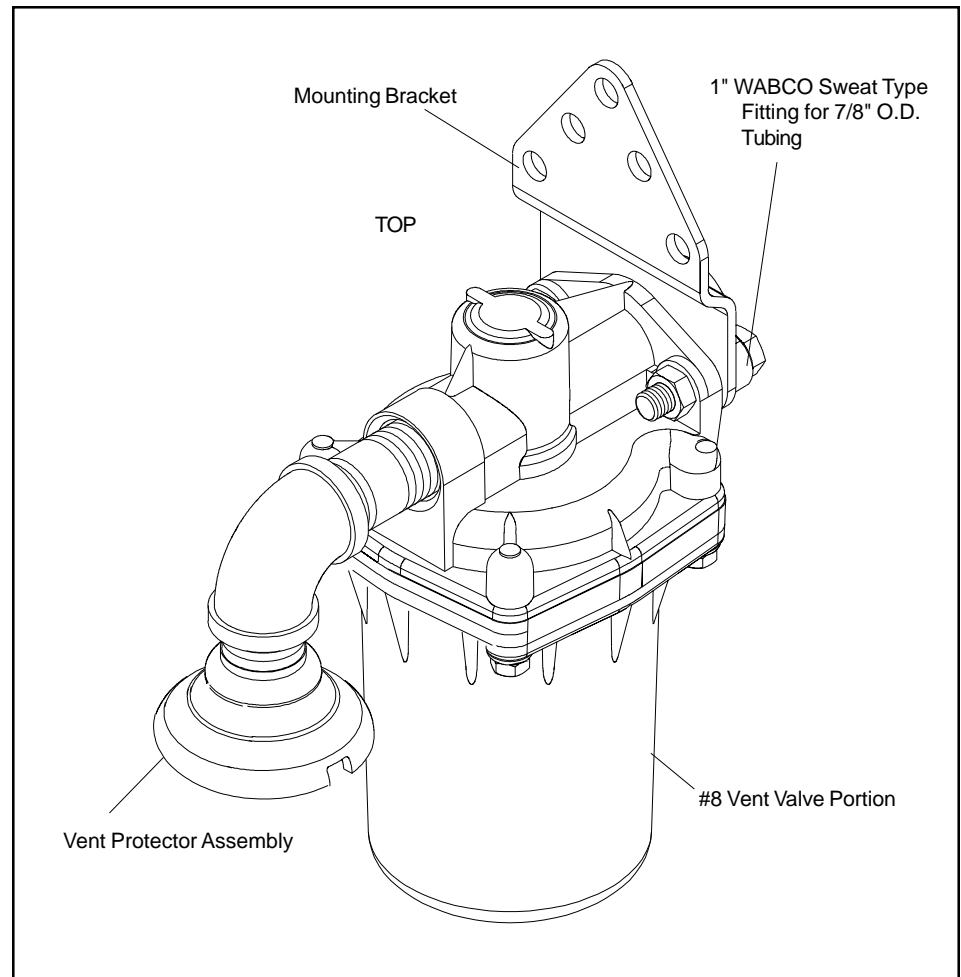

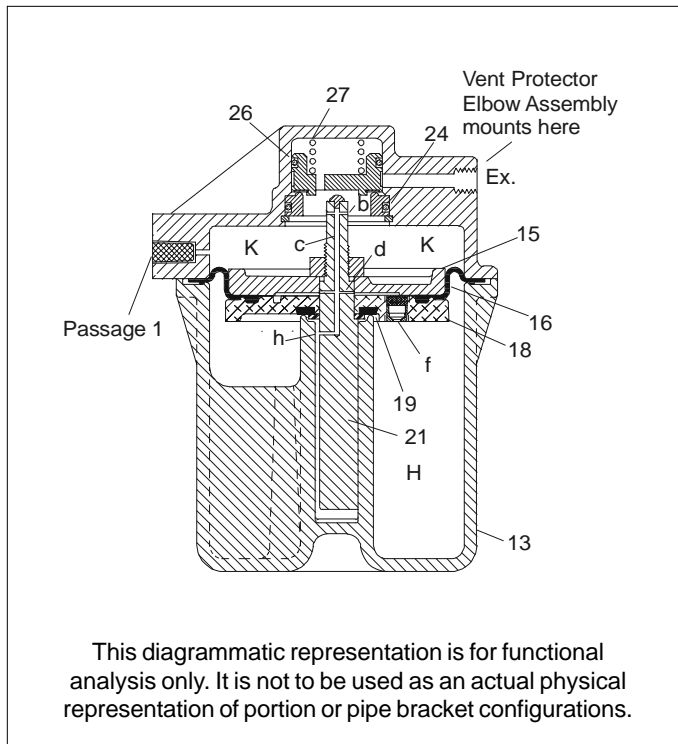

This diagrammatic representation is for functional analysis only. It is not to be used as an actual physical representation of portion or pipe bracket configurations.

Figure 1 - Diagrammatic View
(Shown less Vent Protector -Elbow Assembly)

1.0 DESCRIPTION (Figure 1)

This #8 Vent Valve, which may be used in equipment arrangements where the air pressure does not exceed 150 psig, is comprised of three major components: a #8 Vent Valve Portion, Pc.No. 582555; a Mounting Bracket, Pc.No. 582086; and a 1" WABCO Sweat Type Flange Fitting for $\frac{7}{8}$ " O.D. tubing, Pc.No. 503685.

The mounting bracket, when properly installed, is semi-permanently attached to the body of the vehicle, and the flange fitting, when properly installed, is semi-permanently attached to the piping of the vehicle. These two components are utilized to mount the #8 Vent Valve Portion on the vehicle and to connect it to the vehicle piping. Consult your Wabtec Corporation Representative for specific piping and installation information pertaining to a specific application.

The #8 Vent Valve Portion is a diaphragm operated type valve which functions to deplete brake pipe air locally at a rapid rate to assist in propagating an emergency brake application whenever the main line of brake pipe pressure is reduced at an emergency rate. Operation of the vent valve portion at one location aids in producing an emer-

gency rate of brake pipe pressure reduction at the next vehicle and action of the vent valve portion on each succeeding vehicle of a train consist assists in a fast transmission of an emergency brake signal through an open train line brake pipe.

The #8 Vent Valve Portion is designed so that it can be readily removed from the vehicle for maintenance or repair without disturbing the piping of the vehicle.

NOTE: If it is necessary to have any obstructions in line with the Vent Valve Portion's Vent Protector Assembly, which are located less than 5" from it when the #8 Vent Valve Portion is mounted on the vehicle, the obstruction **MUST BE** provided with a minimum 3.5" diameter opening. This 3.5" opening is to be adequately protected on all sides to prevent any possible build up of any restrictive elements such as an accumulation of ice, snow, mud or other elements which could slow or block the emergency rate of exhausting air pressure.

2.0 OPERATION (Figure 2)

2.1 CHARGING

Brake pipe (B.P.) air flows into passage 1 to charge chamber K. Piston 18 moves downward into release position permitting the force of spring 27 to seat the vent valve exhaust valve 26. Brake pipe air flows through cross-section passage b, passage c, d, f, and h to charge the vent valve chamber H.

2.2 SERVICE

When air pressure is gradually reduced in passage 1, the vent valve volume H reduces in pressure an amount corresponding to this pressure drop in order to maintain this valve in a stabilized position. When the pressure in chamber K is reduced, air from chamber H bleeds down through passages c and b, stabilizing the vent valve piston 18 which prevents any movement during service.

2.3 RELEASE & RECHARGE - AFTER A SERVICE APPLICATION

During pressure reduction in passage 1, the vent valve volume H will reduce in pressure in order to follow the brake pipe pressure reduction. The vent valve portion is recharged as previously described under "charging".



operation & maintenance instruction

2.4 EMERGENCY

When an emergency rate of brake pipe reduction is effective in passage 1, air in chamber H of the vent valve portion cannot flow through passages f, d, c, and b at the same rate as chamber K is being evacuated. This differential of pressure across the piston 18 moves the piston stem 21 upward to contact and unseat exhaust valve 26 providing a large and direct passage for brake pipe air in passage 1 to flow through chamber K to atmosphere. This local rapid venting of brake pipe air accelerates the emergency reduction of brake pipe pressure serially and rapidly through the train by assisting in the prompt movement of similar valves on other vehicles into an emergency position.

2.5 RELEASE AFTER EMERGENCY

When releasing after an emergency brake application, as the brake pipe passage 1 is recharged, the vent valve will recharge as previously described under "charging".

3.0 MAINTENANCE SCHEDULE

IMPORTANT: The #8 Vent Valve Portion should be removed from the vehicle, taken to the shop, be completely disassembled, the parts cleaned, lubricated, assembled, and the portion tested according to the following vehicle application schedule, or more frequently if service conditions so indicate.

RECOMMENDED TYPE OF APPLICATION	FREQUENCY - AT LEAST ONCE EVERY
------------------------------------	------------------------------------

Freight Cars	144 Months
Locomotives	12 Months
Passenger (Interstate)	36 Months
Transit	24 Months

4.0 PARTS CATALOG INFORMATION

When ordering replacement parts, refer to the current issue of the Wabtec Corporation Parts Catalog 3211-4, S.13.

NOTE: The reference numbers used in this publication and those used in the parts catalog may differ. Check the descriptive parts name to be sure that the desired part is ordered.

5.0 SAFETY PROCEDURES AND WARNINGS

Regular shop and operator property safety procedures are to be followed when working on this Valve or any of the component parts.

The work area is to be clean.

WARNINGS

The following statements of warning apply all or in part wherever the symbol appears in the maintenance procedures. Failure to observe these precautions may result in serious injury to those performing the work and/or bystanders.

- **The use of an air jet, which must be less than 30 p.s.i.g., to blow parts clean or to blow them dry after being cleaned with a solvent will cause particles of dirt and/or droplets of the cleaning solvent to be airborne. Wire brushing may also cause particles of dirt, rust, and scale to become airborne. These conditions may cause skin and/or eye irritation.**
- **When using an air jet, do not direct it toward another person. Improper use of air jet could result in bodily injury.**
- **Personal eye protection must be worn when performing any work on this device or its components parts to avoid any possible injury to the eyes.**
- **The use of solvents as cleaning agents and the use of lubricants can involve health and/or safety hazards. The manufacturers of the solvents and lubricants should be contacted for safety data (such as OSHA Form OSHA-20 or its equivalent). The recommended precautions and procedures of the manufacturers should be followed.**
- **When performing any test or work on devices or equipment while they are on the vehicle (on car test, etc.) special precautions must be taken to insure that vehicle movement will not occur which could result in injury to personnel and/or damage to equipment.**
- **Assembly may be under a spring load. Exercise caution during disassembly so that no parts "Fly Out" and cause bodily injury.**
- **All air supply and/or electric current to this device and/or to any components part must be cut-off be-**



fore this device and/or any component part is removed from the equipment arrangement.

- “Bottled” up air under pressure (even though air supply is cut-off) may cause gaskets and/or particles of dirt to become airborne and an increase in sound level when this device and/or any component part is removed from the equipment arrangement.
- Personal eye and ear protection must be worn and care taken to avoid possible injury when performing any work on this device and/or component part.
- An adequate support or lifting device must be available to support the Device and/or Valve Portion(s) during removal, installation and maintenance procedures.

6.0 CLEANING SOLVENT & LUBRICANTS

6.1 The solvent used to clean the parts MUST BE an aliphatic, organic solution, such as mineral spirits or naphtha, that will dissolve oil and grease and that will permit all parts to be cleaned without abrasion.

6.2 #2 Silicone Grease, Wabtec Corporation Specification M-7680-2, is to be used to lubricate all o-rings, o-ring grooves, and the bearing surfaces of the bushings into which the o-ring assemblies are installed.

6.3 Triple Valve Oil, Wabtec Corporation Specification M-7611-20, is to be used to lubricate the piston stem guide (piston tail) of the Vent Valve Portion.

7.0 SPECIAL TOOLS

In addition to the regular shop tools, the following are to be available:

- 7.1 #3 TRUARC Retaining Ring Pliers.
- 7.2 An $1\frac{1}{16}$ " open end wrench.
- 7.3 A perfectly flat cast iron lapping plate.
- 7.4 Float emery.
- 7.5 A piece of $\frac{1}{16}$ " diameter drill rod.

8.0 REMOVAL & INSTALLATION OF THE #8 VENT VALVE PORTION — “ON-CAR”

8.1 ALL owner operator safety procedures and the WARNINGS listed in Section 5.0 MUST BE adhered to.

8.2 Vehicle wheels MUST BE chocked to prevent vehicle movement.

8.3 Place adequate WARNING placards in the cab and work areas indicating that work is being performed on the vehicle.

8.4 ALL air supply to the #8 Vent Valve is to be cut-off.

8.5 The repair person will require the following items:

(Figure 1)

8.5.1 A NEW or repaired and tested #8 Vent Valve Portion, Pc.No. 582555.

NOTE: Be sure that the 1" O.D. ring gasket (6) and strainer (28) are properly positioned in the vent valve portion body (29).

8.5.2 A NEW 1" O.D. ring gasket (5).

8.5.3 Two NEW $\frac{1}{2}$ " self-locking hex nuts (1).

8.6 Remove ALL free dirt from the exterior surfaces of the Vent Valve Portion and mounting bracket by wiping with a lint-free cloth, or blow clean using a low pressure jet of clean, dry air.

8.7 Remove the Vent Valve Portion from the mounting bracket (2) by removing the two $\frac{1}{2}$ " self-locking hex nuts (2) and $\frac{1}{2}$ " x 2" hex head screws (3). SCRAP the self-locking nuts.

8.8 Remove and SCRAP the 1" O.D. ring gasket (5) from the mounting face of the flange fitting (4).

8.9 Visually inspect the mounting bracket (2) and flange fitting (4). They do not have to be removed from the equipment arrangement unless they are damaged.

8.10 Install a NEW 1" O.D. ring gasket (5) in place in its groove in the flange fitting (4).

8.11 Remove all protective material from the NEW or repaired and tested Vent Valve Portion. Be sure that the strainer (28) and 1" O.D. ring gasket (6) are in place in the vent valve portion body (29). The gasket (6) and strainer (28) are a part of the Vent Valve Portion.

8.12 Place the Vent Valve Portion on the mounting bracket (2) and secure it and the flange fitting (4) with gasket (5) in position by installing the two $\frac{1}{2}$ " x 2" hex head screws (3) and NEW $\frac{1}{2}$ " self-locking nuts (1). Equally tighten the nuts and then torque them to 40 to 50 foot-pounds.

operation & maintenance instruction

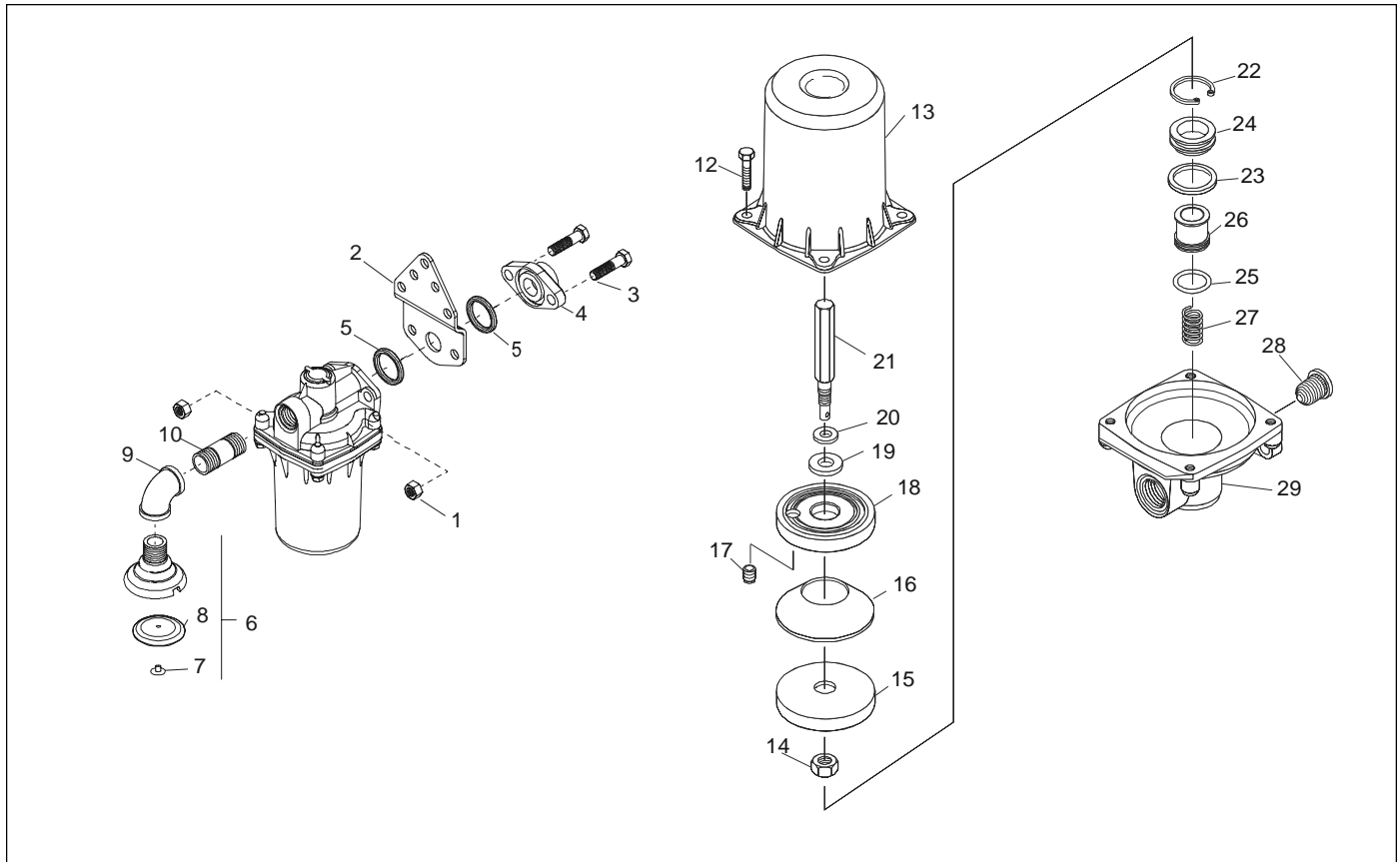

Figure 3 - Exploded View

8.13 Transport the removed Vent Valve Portion to the shop area for maintenance or repair. Provide adequate protection to keep dirt and/or moisture from entering the Portion.

8.14 **IMPORTANT:** When any Portion or component part of the #8 Vent Valve is removed from an equipment arrangement for any reason, and it is replaced with a NEW or repaired and tested Portion or component part, a stationary vehicle Air Brake Test must be made to be sure that the Portion functions properly in the brake equipment arrangement.

8.15 Charge the Brake Pipe; this will direct air flow to the Vent Valve. Remove ALL WARNING placards and the wheel chocks before attempting to move the vehicle.

9.0 #8 VENT VALVE PORTION - MAINTENANCE PROCEDURES "IN-SHOP"

9.1 DISASSEMBLY (Figure 3)

NOTE: DO NOT use sharp or hard metal tools to remove o-rings, gaskets, seals, or the rubber diaphragm. Exercise

care so that NO damage is done to metal parts.

9.1.1 Remove the vent protector assembly (6) from the elbow (9).

9.1.2 Remove the elbow (9) from the pipe nipple (10) and the nipple (10) from the vent valve body (29).

9.1.3 Remove the four 3/8" x 1" hex head cap screws (12) that secure the diaphragm housing (13) to the body (29).

9.1.4 Remove the diaphragm housing with the diaphragm piston assembly (13 to 21) as a unit from the body (29).

9.1.5 Remove the diaphragm piston assembly (14 to 21) from the diaphragm housing (13).

9.1.6 Disassemble the diaphragm piston assembly (14 to 21) as follows:

9.1.6.1 Hold the piston stem (21) with an 11/16" open end wrench and remove the 1/2" lock nut (14) from the piston stem (21). SCRAP the locknut.

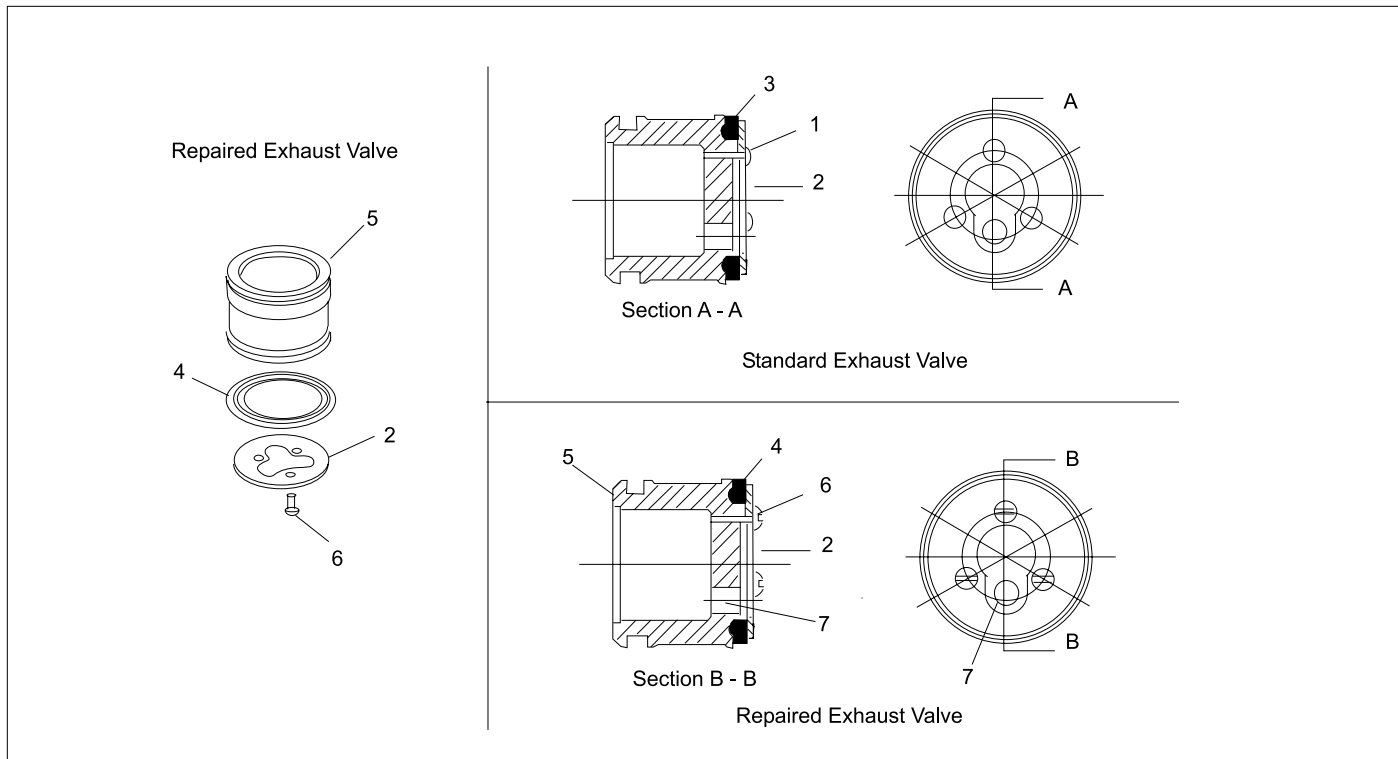

Figure 4 - Exhaust Valve

9.1.6.2 Remove the diaphragm follower (15), diaphragm (16), piston with seal and felt choke assembly (17, 18, 19) and washer (20) from the piston stem (21). **SCRAP** the diaphragm (16).

9.1.7 Remove the felt choke (17) and rubber seal (19) from the piston (18). **SCRAP** the seal (19).

9.1.8 **CAUTION:** To avoid possible injuries, exercise care during the following procedures so that no parts are inadvertently expelled from the assembly.

Carefully depress the exhaust valve seat (24), valve (26) and spring (27) into the vent valve body (29), then using #3 TRUARC Retaining Ring Pliers, remove the retaining ring (22) from the body (29).

9.1.9 Remove the exhaust valve seat with o-ring (24, 23), exhaust valve with o-ring (26, 25) and spring (27) from the body (29).

9.1.9.1 **NOTE:** If the exhaust valve (26) sticks, use a piece of stiff wire with the end bent and insert it through the drilled hole to hook the valve and pull it out of the body.

9.1.10 Remove and **SCRAP** the 1³/₄" O.D. o-ring (23) from the exhaust valve seat (24).

9.1.11 Remove and **SCRAP** the 1¹/₂" O.D. o-ring (25) from

the exhaust valve (26).

9.1.12 Remove and **SCRAP** the 1" O.D. ring gasket (6) from the mounting face of the body (29).

9.1.13 Remove the strainer (28) from the opening in the body (29).

⚠ 9.2 CLEANING & INSPECTING

9.2.1 NON-REUSABLE PARTS

ALL gaskets, o-rings, self-locking nuts, the sealing wire, and the diaphragm are to be **SCRAPPED** and replaced with NEW Wabtec Corporation parts.

NOTE: A Rubber Parts Maintenance Kit is available by ordering Pc.No. 589793. See Parts Catalog 3211-4, S.13 for parts included in this kit.

9.2.2 FELT CHOKE

9.2.2.1 The felt choke (17) is to be air cleaned by blowing with a low pressure jet of clean, dry air.

9.2.2.2 If the felt choke (17) cannot be easily cleaned or if it is damaged in any way it is to be **SCRAPPED** and replaced with a NEW part.



operation & maintenance instruction

⚠ 9.2.3 EXHAUST VALVE

9.2.3.1 Clean the exhaust valve (26) by dipping it in a bath of the cleaning solvent as described in Section 6.1. DO NOT allow the exhaust valve to soak in the cleaning solution. Promptly wipe the exterior and interior surfaces with a lint-free cloth and blow the valve completely dry using a low pressure jet of clean dry air.

9.2.3.2 Inspect the seal of the exhaust valve (26). If it is cracked, cut or worn excessively, it MUST BE replaced according to the following procedure. (Figure 4)

9.2.3.2.1 Use a piece of $1/16$ " diameter drill rod to drive out the three driven fasteners (1), then remove the seal retainer (2) and seal (3). SCRAP the fasteners (1), and seal (3).

9.2.3.2.2 Place a NEW seal (4) Pc.No. 568992 on the exhaust valve (5) with the bead of the seal in the groove of the exhaust valve.

9.2.3.2.3 Position the retainer (2) Pc.No. 568995 in place on the seal (4).

⚠ **WARNING:** BE SURE THAT THE RETAINER DOES NOT COVER THE EXHAUST VALVE HOLE (7) IN ANY WAY.

If the exhaust valve hole is restricted, improper Vent Valve operation could result which could lead to possible injury to personnel and/or equipment damage.

9.2.3.2.4 Using three NEW #3 self-tapping screws (6), Pc.No. 584117, secure the seal retainer (2) in place. Torque the screws to a maximum of 9.0 inch-pounds.

⚠ 9.2.4 VENT PROTECTOR ASSEMBLY

9.2.4.1 Clean the exterior surfaces of the vent protector assembly (6) by wiping with a clean, lint-free cloth that has been saturated with the cleaning solvent described in Section 6.1.

9.2.4.2 After cleaning, blow the assembly completely dry using a low pressure jet of clean, dry air.

9.2.4.3 Inspect the assembly. If the body of the assembly is damaged or bent the assembly is to be replaced. If the seal (8) is cracked, cut, torn or damaged, or if the rivet (7) is bent or damaged a NEW seal (8) and rivet (7) are to be installed. When installing a NEW seal (8), Pc.No. 502465, a NEW $3/16$ " x $1/2$ " aluminum pop rivet (7), Pc.No. 571140, MUST BE used.

⚠ 9.2.5 REMAINING PARTS

9.2.5.1 Wash all of the remaining parts in the cleaning

solvent described in Section 6.1.

9.2.5.2 The spring may be wire brushed to assist in the removal of any dirt, rust or scale.

9.2.5.3 Visually inspect the choke passages in piston (18) and piston stem (21) to be sure that they are clear and unrestricted. These passages may be cleaned by blowing with a low pressure jet of clean, dry air.

DO NOT use metallic tools to clean chokes as their size and shape MUST NOT be changed.

9.2.5.4 After the parts are cleaned they are to be blown completely dry using a low pressure jet of clean, dry air.

9.2.5.5 Inspect the spring (27). It is to be replaced if it is rusted, pitted, distorted, damaged in any way, or if it has taken a permanent set. Refer to Parts Catalog 3211-4, S.13 for spring information and identification.

9.2.5.6 Inspect the retaining ring (22). It MUST BE elastic enough to hold securely. During assembly it MUST "snap" tightly into its groove.

9.2.5.7 Inspect the exhaust valve seat (24) to be sure that it is not scratched, scored, or damaged. If the valve seat requires reconditioning, the following recommended procedures are to be followed:

9.2.5.7.1 Use a perfectly flat cast iron lapping plate. Apply float emery to the entire surface of the plate. Condition the plate by rubbing in with a piece of flat brass such as a brass rotary valve which has a ground finished surface.

9.2.5.7.2 Lap the valve seat on the lapping plate by holding the valve flat and using a rotary motion.

CAUTION: NO MORE than 0.010" may be removed from the original valve seat thickness. Original thickness is 0.469".

9.2.5.7.3 Wipe the valve seat clean, using a clean, lint-free cloth that has been saturated with the cleaning solvent described in Section 6.1. Blow the seat completely dry with a low pressure jet of clean, dry air.

Visually inspect the valve seat surface. it should be perfectly smooth.

9.2.5.8 Inspect the remaining parts. Replace any part that is cracked, cut, broken, excessively worn, damaged in any way, or that is in such a condition that may result in the unsatisfactory operation of the #8 Vent Valve Portion.

9.3 ASSEMBLY (Figure 3)

9.3.1 Using #2 Silicone Grease, Wabtec Corporation



operation & maintenance instruction

Specification M-7680-2, lubricate the surfaces of a NEW $1\frac{1}{2}$ " O.D. o-ring (25) and a NEW $1\frac{3}{4}$ " O.D. o-ring (23). Also fill the o-ring grooves on the exhaust valve seat (24) and the exhaust valve (26) and lightly lubricate the exhaust valve bushing in the vent valve body (29) with the lubricant.

9.3.2 Install the NEW lubricated $1\frac{1}{2}$ " O.D. o-ring (25) into its groove on the exhaust valve (26). Remove any excess lubricant by wiping with a clean, dry, lint-free cloth.

9.3.3 Install the NEW lubricated $1\frac{3}{4}$ " O.D. o-ring (23) into its groove on the exhaust valve seat (24). Remove any excess lubricant by wiping with a clean, dry, lint-free cloth.

9.3.4 Install the exhaust valve spring (27), exhaust valve with o-ring assembly (25, 26) and exhaust valve seat with o-ring (23, 24) into the vent valve body (29).

9.3.5 Exercising care so that no parts are inadvertently expelled from the body (29) carefully press the valve seat (24) into the vent valve body (29) far enough to expose the retaining ring groove. Install the retaining ring (22) so that it "snaps" into its groove.

Slowly release the valve seat (24).

9.3.6 Assemble the diaphragm piston assembly (14 to 21) as follows:

9.3.6.1 Install a NEW rubber piston seal (19) and the felt choke strainer (17) into the piston (18).

9.3.6.2 Place the washer (20) and piston assembly (17, 18, 19) on the piston stem (21) with the felt choke (17) toward the threaded end of the piston stem.

9.3.6.3 Place a NEW diaphragm (16) on the piston (18) with the bead of the diaphragm (16) down into the groove of the piston (18).

9.3.6.4 Place the diaphragm follower (15) on the diaphragm (16) with the ribbed side of the follower toward the threaded end of the piston stem (21).

9.3.6.5 Hold the piston stem (21) with an $1\frac{1}{16}$ " open end wrench. Install a NEW $\frac{1}{2}$ " lock nut (14) on the piston stem (21). Tighten the nut (14) to secure the parts of the diaphragm piston assembly together.

9.3.7 Lubricate the tail of the piston guide stem (21) with Triple Valve Oil, Wabtec Corporation Specification M-7611-20. Install the diaphragm piston assembly (14 to 21) into the diaphragm housing (13) with the bead of the diaphragm (16) in the groove in the diaphragm housing (13).

9.3.8 Place the body (29) in position on the diaphragm housing (13) and secure it in place with four $\frac{3}{8}$ " x 1" hex head cap screws (12). Equally tighten the screws (12).

9.3.9 Install a NEW 1" O.D. ring gasket (5) in the proper groove on the mounting face of the body (29).

9.3.10 Install the strainer (28) into the port on the mounting face of the body (29).

9.3.11 Apply a light coating of Loctite Sealant with Teflon, Wabtec Corporation Specification M-7499-15, to the threads of the 3" x 1" NPT pipe nipple (10), the threads of the 90° x 1" NPT elbow (9), and the threads of the vent protector assembly (6).

9.3.12 Install the pipe nipple (10) into the vent valve body (29).

9.3.13 Install the 90° elbow (9) on the pipe nipple (10) and tighten. The elbow is to be installed so that when it is tightened the open end (tapped end) faces toward the diaphragm housing (13).

9.3.14 Install the vent protector assembly (6) into the elbow (9).

10.0 TESTING & ADDITIONAL INFORMATION

10.1 After the #8 Vent Valve Portion is assembled, BUT BEFORE it is returned to service it MUST PASS a series of tests following the procedures of the current issue of the Wabtec Corporation Test Specification T-3597-O.

IMPORTANT: #8 Vent Valve Portion Pc.No. 582555 is to be tested with the vent protector assembly (6) assembled in place.

10.2 See Section 8.0 for installation of #8 Vent Valve Portion on car.

10.3 Consult your Wabtec Corporation Representative if additional information is required.

WABCO Locomotive Products

1001 Air Brake Avenue • Wilmerding, PA 15148

(412) 825-1000 • Fax (412) 825-1019

www.wabtec.com