

SA-26 INDEPENDENT BRAKE VALVE

Revised Lubrication Requirements

OCTOBER, 1996

This Service Bulletin is being issued to revise certain lubrication procedures for the SA-26 Independent Brake Valve done at certified air brake shops. The appropriate Operation and Maintenance Information will be revised accordingly.

Lubricant:

1. Spindle Grease. "Tufoil" brand high temperature spindle grease, a product of Fluoramics Inc., 18 Industrial Avenue, Mahwah, New Jersey, 07430-2208.

Note 1: IMPORTANT. Care must be taken to prevent any application of spindle grease to the O-rings, O-ring grooves, and O-ring bearing surfaces. **The existing Operation and Maintenance Information requirements for O-ring lubrication remain the same.** The O-rings, O-ring grooves and O-ring bearing surfaces must be lubricated with Number 2 Silicone Grease, Wabtec Corporation Specification M-07680-02, such as Dow Corning Corporation, Dow Corning #55.

Note 2: IMPORTANT. Extreme care must be taken to prevent lubricant of any kind from being applied to either the outside diameter of the cam dog roller where it contacts the cam, or the area of roller contact on the cam itself. The contacting surfaces of both of these parts must be maintained clean and dry to retain rolling friction which will prevent any sliding action.

service bulletin

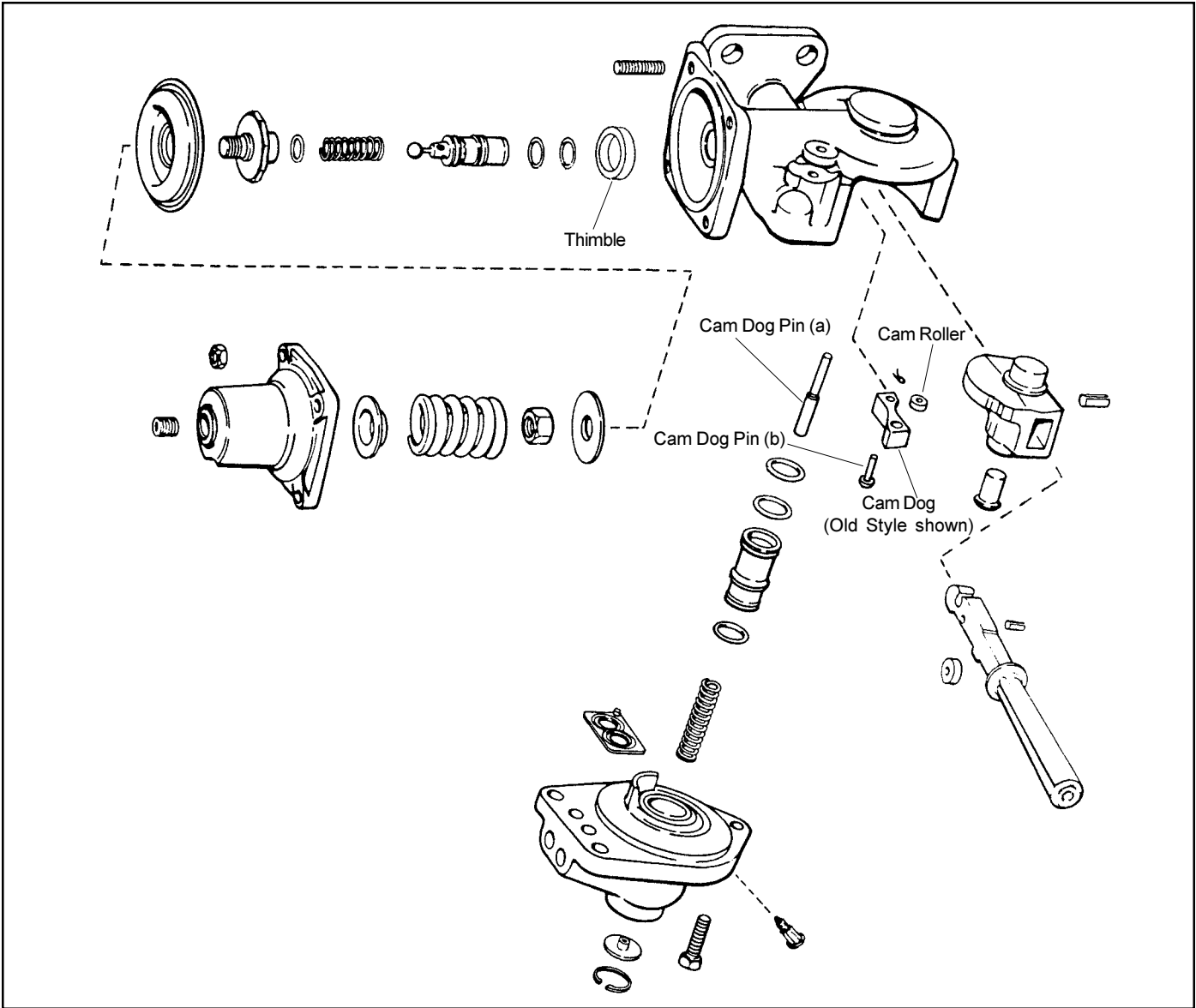

Figure 1 - Exploded View SA-26 Independent Brake Valve

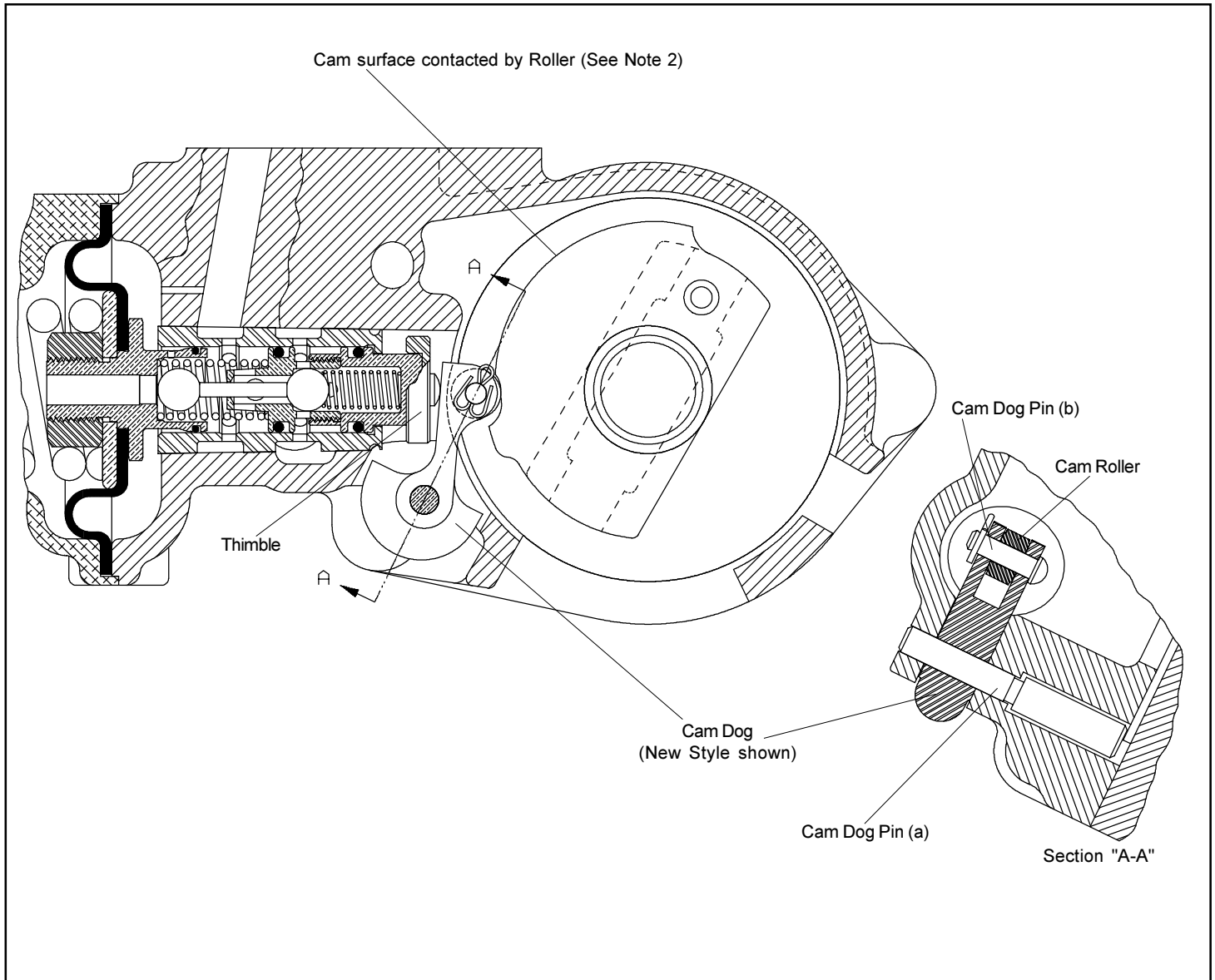

Figure 2 - Partial Cross Sectional View

service bulletin

1. Apply a light coating of spindle grease to the tip of the **Thimble** and the surface of contact on either style of the **Cam Dog**. (See Figure 3).

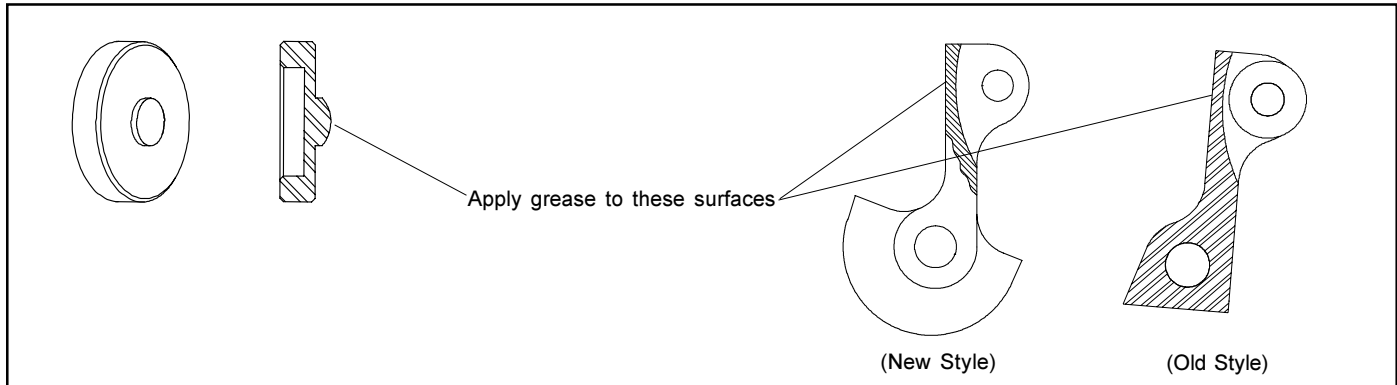

Figure 3 - Thimble (2 views) and Cam Dogs

2. Apply a light coating of spindle grease to the outside diameter of the two different **Cam Dog Pins**, and to the inside diameter of the holes in the **Cam Dog** (either style), **Brake Valve Body** and **Cam Roller**. (See Figure 4).

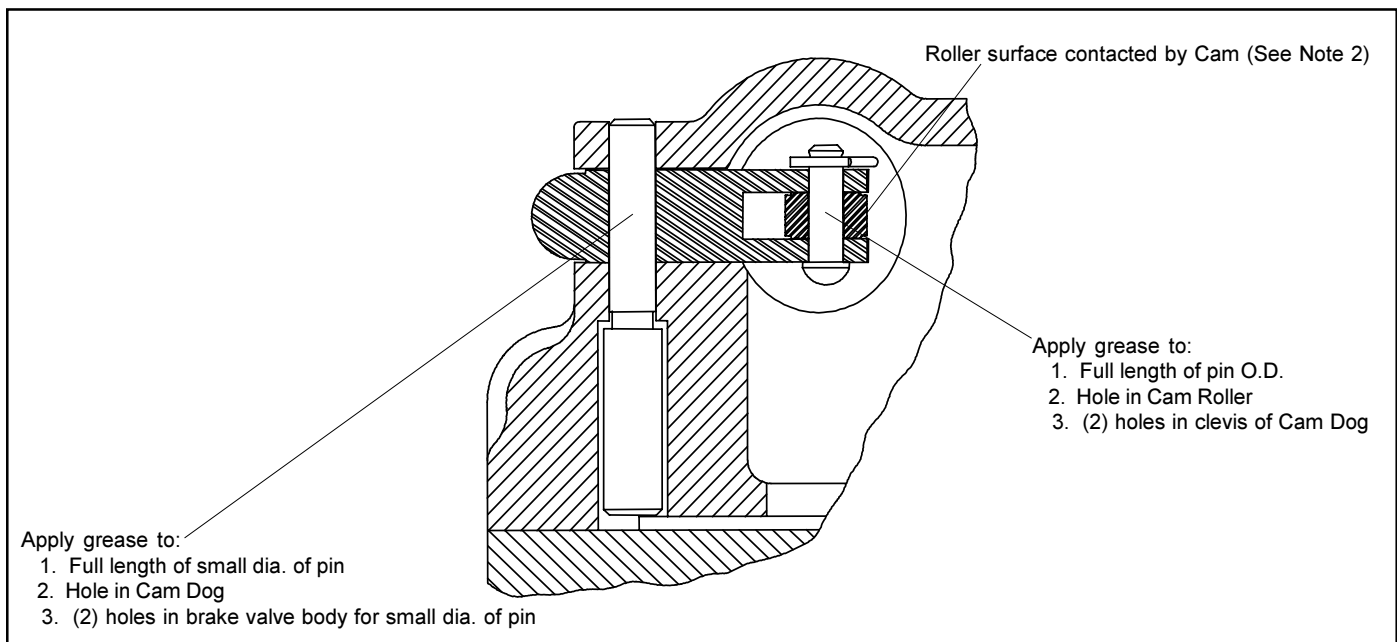

Figure 4 - Cam Dog (New Style shown), Cam Roller, Cam Dog Pins

Wabtec Corporation
1001 Air Brake Avenue
Wilmerding, Pennsylvania 15148
(412) 825-1000 • Fax (412) 825-1019